

# BC680R

Intel® R680E support 12/13<sup>th</sup> generation Core™ i9, Core i7,  
Core i5, Core i3, Pentium, Celeron  
ATX Motherboard

## User's Manual

---

Ver. 1.2

# Content

<b>Safety Information</b> .....	<b>5</b>
<b>About this guide</b> .....	<b>7</b>
<b>Typography</b> .....	<b>8</b>
<b>Packing List</b> .....	<b>9</b>
<b>Revision History</b> .....	<b>10</b>
<b>Specifications Summary</b> .....	<b>12</b>
1.1 Before you Proceed .....	15
1.2 Motherboard Overview.....	15
1.2.1 Placement Direction .....	15
1.2.2 Screw Holes .....	15
1.2.3 Motherboard Layout.....	17
1.2.4 Layout Content List .....	17
1.3 Central Processing Unit (CPU) .....	19
1.3.1 Installing the CPU .....	20
1.3.2 Installing the CPU Heatsink and Fan .....	22
1.3.3 Uninstalling the CPU Heatsink and Fan.....	23
1.4 System Memory .....	25
1.4.1 Overview .....	25
1.4.2 Installing a DIMM .....	26
1.4.3 Removing a DDR5 DIMM .....	26
1.5 Expansion Card .....	27
1.5.1 Installing an Expansion Card .....	27
1.5.2 Configuring an Expansion Card .....	27
1.5.3 PCI Express x16 slot.....	27
1.5.4 PCI Express x1 slot.....	28
1.5.5 M.2 connector .....	28
1.6 Jumpers .....	29
1.6.1 Clear CMOS (CLCMOS1) .....	29
1.6.2 AT/ATX Power Mode Select (JPSON1).....	30
1.6.3 COM POWER SETTING (JCOMPWR1~6) .....	31
1.7 Connectors.....	31
1.7.1 Rear panel connectors .....	31
1.7.2 CPU and System fan connectors (CPU_FAN1, CHA_FAN1, CHA_FAN2).....	32
1.7.3 System Panel (F_PANEL) .....	33
1.7.4 ATX power connectors (ATX1 & ATX12V1) .....	34
1.7.5 Serial Port connectors (COM1~6).....	34
1.7.6 Serial ATA Connector (SATA1~4 ) .....	35
1.7.7 USB connectors (USB1011, USB1213, USB1415, USB1617).....	35

1.7.8 USB3.2 connector (USB89) .....	36
1.7.9 8 bit GPIO header (JDIO1).....	37
1.7.10 Front Audio connector (FP_AUDIO1) .....	38
1.7.11 Amplifier Connector (JAMP1).....	38
1.7.12 SM bus connector (SMB1) .....	39
1.7.13 LAN LED status connector (LANLED1) .....	39
1.7.14 Chassis intrusion connector (JCASE1) .....	40
<b>Chapter 2 - BIOS Setup .....</b>	<b>42</b>
2.1 BIOS Setup Program .....	42
2.1.1 Legend Box .....	43
2.1.2 List Box.....	43
2.1.3 Sub-menu.....	43
2.2 BIOS Menu Screen .....	44
2.3 Main Setup.....	45
2.4 Advanced BIOS Setup .....	46
2.4.1 CPU Configuration .....	47
2.4.2 Power & Performance .....	48
2.4.3 PCH-FW configuration .....	49
2.4.4 Thunderbolt™ Configuration (optional feature).....	50
2.4.5 Trusted Computing.....	51
2.4.6 ACPI Settings .....	52
2.4.7 NCT6126D Super IO configuration .....	53
2.4.7.1 Serial Port 1 Configuration.....	54
2.4.7.2 Serial Port 2 Configuration.....	54
2.4.7.3 Serial Port 3 Configuration.....	55
2.4.7.4 Serial Port 4 Configuration.....	56
2.4.7.5 Serial Port 5 Configuration.....	57
2.4.7.6 Serial Port 6 Configuration.....	58
2.4.8 Hardware monitor .....	59
2.4.8.1 Smart FAN .....	59
- 2.4.8.1.1 Smart FAN mode Configuration.....	60
2.4.9 S5 RTC wake settings.....	61
2.4.10 Serial Port Console Redirection .....	62
2.4.10.1 Console Redirection settings .....	62
2.4.11 Intel TXT information .....	64
2.4.12 USB configuration .....	65
2.4.13 Network Stack Configuration.....	66
2.4.14 IP configuration .....	67
2.4.15 NVMe Configuration .....	67
2.4.16 Remote Server Configuration.....	69

## BC680R User's Manual

2.5 Chipset.....	70
2.5.1 System Agent (SA) Configuration .....	71
2.5.1.1 Memory Configuration.....	71
2.5.1.2 Graphic Configuration.....	72
2.5.1.3 VMD setup menu .....	73
2.5.1.4 PCI Express Configuration.....	74
- 2.5.1.4.1 PCI Express Root Port 1 (x4 Key M).....	74
- 2.5.1.4.2 PCI Express Root Port 2 (x16 Slot 2) .....	75
2.5.2 PCH-IO Configuration .....	77
2.5.2.1 PCI Express Configuration.....	78
- 2.5.2.1.1 PCI Express Root Port 1(x4 slot3) .....	78
- 2.5.2.1.2 PCI Express Root Port 5(x1 Slot 1) .....	80
- 2.5.2.1.3 PCI Express Root Port 6(X1 Slot 5).....	81
- 2.5.2.1.4 PCI Express Root Port 7(x1 slot 6) .....	82
- 2.5.2.1.5 PCI Express Root Port 8(x1 keyE).....	82
- 2.5.2.1.6 PCI Express Root Port 13(x4 Key M).....	83
- 2.5.2.1.7 PCI Express Root Port 21(x4 slot 4) .....	84
- 2.5.2.1.8 PCI Express Root Port 25(x4 slot 7) .....	85
2.5.2.2 SATA Configuration .....	87
2.5.2.3 USB Configuration.....	88
2.5.2.4 HD audio Configuration .....	89
2.5.2.5 Serial IO Configuration .....	90
2.6 Security .....	91
2.7 Boot .....	92
2.8 Save & Exit .....	93

## Safety Information

### Electrical safety

- To prevent electrical shock hazard, disconnect the power cable from the electrical outlet before relocating the system.
- When adding or removing devices to or from the system, ensure that the power cables for the devices are unplugged before the signal cables are connected. If possible, disconnect all power cables from the existing system before you add a device.
- Before connecting or removing signal cables from the motherboard, ensure that all power cables are unplugged.
- Seek professional assistance before using an adapter or extension cord. These devices could interrupt the grounding circuit.
- Make sure that your power supply is set to the correct voltage in your area. If you are not sure about the voltage of the electrical outlet you are using, contact your local power company.
- If the power supply is broken, do not try to fix it by yourself. Contact a qualified service technician or your retailer.

### Operation safety

- Before installing the motherboard and adding devices on it, carefully read all the manuals that came with the package.
- Before using the product, make sure all cables are correctly connected and the power cables are not damaged. If you detect any damage, contact your dealer immediately.
- To avoid short circuits, keep paper clips, screws, and staples away from connectors, slots, sockets and circuitry.
- Avoid dust, humidity, and temperature extremes. Do not place the product in any area where it may become wet.
- Place the product on a stable surface.
- If you encounter technical problems with the product, contact a qualified service technician or your retailer.



The symbol of the crossed out wheeled bin indicates that the product (electrical and electronic equipment) should not be placed in municipal waste. Check local regulations for disposal of electronic products.

## **Safety Declaration**

This device complies with the requirements in Part 15 of the FCC rules. Operation is subject to the following two conditions:

- This device may not cause harmful interference.
- This device must accept any interference received, including interference that may cause undesired operation.

## About this guide

This user guide contains the information you need when installing and configuring the motherboard.

## How this guide is organized

This manual contains the following parts:

- **Chapter 1: Product introduction**

This chapter describes the features of the motherboard and the new technology it supports. This chapter also lists the hardware setup procedures that you have to perform when installing system components. It includes description of the jumpers and connectors on the motherboard.

- **Chapter 2: BIOS setup**

This chapter tells how to change system settings through the BIOS Setup menus. Detailed descriptions of the BIOS parameters are also provided.

## Where to find more information

Refer to the following sources for additional information and for product and software updates.

### 1. Technical Support

If a problem arises with your system and no solution can be obtained from the user's manual, please contact your place of purchase or local distributor.

### 2. Optional documentation

Your product package may include optional documentation, such as warranty flyers, that may have been added by your dealer. These documents are not part of the standard package.

## Conventions used in this guide

To make sure that you perform certain tasks properly, take note of the following symbols used throughout this manual.



**DANGER/WARNING:** Information to prevent injury to yourself when trying to complete a task.



**CAUTION:** Information to prevent damage to the components when trying to complete a task.



**IMPORTANT:** Instructions that you **MUST** follow to complete a task.



**NOTE:** Tips and additional information to help you complete a task.

## Typography

<b>Bold text</b>	Indicates a menu or an item to select
<i>Italics</i>	Used to emphasize a word or a phrase
<Key>	Keys enclosed in the less-than and greater-than sign means that you must press the enclosed key Example: <Enter> means that you must press the Enter or Return key
<Key1>+<Key2>+<Key3>	If you must press two or more keys simultaneously, the key names are linked with a plus sign (+) Example: <Ctrl>+<Alt>+<D>
<b>Command</b>	Means that you must type the command exactly as shown, then supply the required item or value enclosed in brackets Example: At the DOS prompt, type the command line: <b>afudos /[filename] /P /B /N /X</b> <b>afudos /71831100.ROM /P /B /N /X</b>



## Packing List

Before you begin installing your single board, please make sure that the following materials have been shipped:

- 1 x BC680R ATX Main board
- 1 x I/O Shield



If any of the above items is damaged or missing, please contact your retailer.

## Revision History

Revision	Revision History	Date
V 0.1	First release version	July, 2022
V1.0	DDR5 memory updated to up to 4400Mhz	February, 2023
V1.1	Update Amplifier spec. from 3W to 6W	October, 2023

This chapter describes the motherboard features and the new technologies it supports.

# 1

## **Product Introduction**

# Specifications Summary

Specifications	
<b>System</b>	
<b>CPU</b>	LGA 1700 Socket supports Intel® Alder/Raptor Lake Core™ i9, Core™ i7, Core™ i5, Core™ i3, Pentium, Celeron Processor up to 16 Cores 24 Threads Hybrid
<b>BIOS</b>	Socket Type 256Mb SPI BIOS
<b>System Chipset</b>	Intel® R680E PCH
<b>Memory</b>	4 x DIMM Up to 128GB Max Dual Channel DDR5 4400 MHz with ECC Support
<b>Watchdog Timer</b>	1 ~ 255 sec timer
<b>H/W Status Monitor</b>	CPU & system temperature monitoring Voltages monitoring
<b>Expansion Slots</b>	1 x Gen 5 PCIe x16 (x16 Physical Black) (Slot 2) 2 x Gen 4 PCIe x4 (x16 Physical Yellow) (Slot 4 & 7) 1 x Gen 3 PCIe x4 (x16 Physical Yellow) (Slot 3) 1 x Gen 3 PCIe x1 (x16 Physical Yellow) (Slot 6) 2 x Gen 3 PCIe x1 Open Ended (Slot 5 & 1) 1 x M.2 2242/2280/22110 M Key NVMe (PCIe x4 + SATA III) 1 x M.2 2242/2280/22110 M Key NVMe (PCIe x4 Only) 1 x M.2 2230 E Key with CNVi Support (PCIe x 1 + USB 2.0)
<b>Smart Fan Control</b>	Yes
<b>Display</b>	
<b>Chipset</b>	Intel® Integrated Iris Xe Graphic (CPU Dependent)
<b>Display Memory</b>	Shared Memory
<b>Ethernet</b>	
<b>LAN1</b>	Intel® I225-LM 2.5 Gigabit Ethernet Controller
<b>LAN2</b>	Intel® I225-LM 2.5 Gigabit Ethernet Controller
<b>Back I/O Port</b>	
<b>Back Panel</b>	2 x HDMI Connectors 2 x DisplayPort Connectors 2 x RJ45+Dual USB 3.2 Stacked Connectors (4 x USB 3.2 Gen 2x1 Ports) 2 x USB 3.2 Gen 2x1 Type-A Connectors 1 x USB 3.2 Gen 2x2 Type-C Connector 1 x 2 ports Audio Jack, Line out (green color) and Mic in (Pink color)
<b>Internal I/O Connector</b>	
<b>Internal I/O</b>	4 x SATA III Vertical Connectors (Red) 5 x RS-232 Headers with Voltage Selection (2.0mm Pitch) 1 x RS-232/422/485 Headers with Voltage Selection (2.0mm Pitch) 1 x PS/2 Header

- 1 x Thunderbolt Header(optional)
- 4 x USB 2.0 Headers with Shroud (8 Ports on Header)
- 1 x USB 3.2 Gen 1 Header with Shroud (2 Ports on Header)
- 1 x SPI Header (2.54mm Pitch)
- 1 x I2C Header
- 1 x SMBus Header
- 1 x Front Audio Header with Shroud (2.54mm Pitch)
- 1 x Amplifier Locking Type Header (2.0mm Pitch)
- 1 x Front Panel Headers with Shroud (2.54mm Pitch)
- 1 x 8 bits GPIO Header with Shroud
- 1 x 4 Pin CPU Fan Header (4 Pin PWM)
- 2 x 4 Pin Chassis Fan Header (4 Pin PWM)
- 1 x 2 LAN Status LED Headers (2 x 5 pin header)
- 1 x Horizontal Socket Type CMOS Battery Holder
- 1 x Chassis Intrusion Locking Type Header
- 1 x Std. 24 pin ATX Connector
- 1 x 8 pin ATX 12 Connector

**Mechanical & Environmental**

<b>Operating Temperature</b>	0~60°C (32~140°F)
<b>Operating Humidity</b>	5%~90% relative humidity, non-condensing
<b>Size (L x W)</b>	12" (L) x 9.6" (W) (305mm x 244mm)

# BC680R User's Manual

## Block Diagram

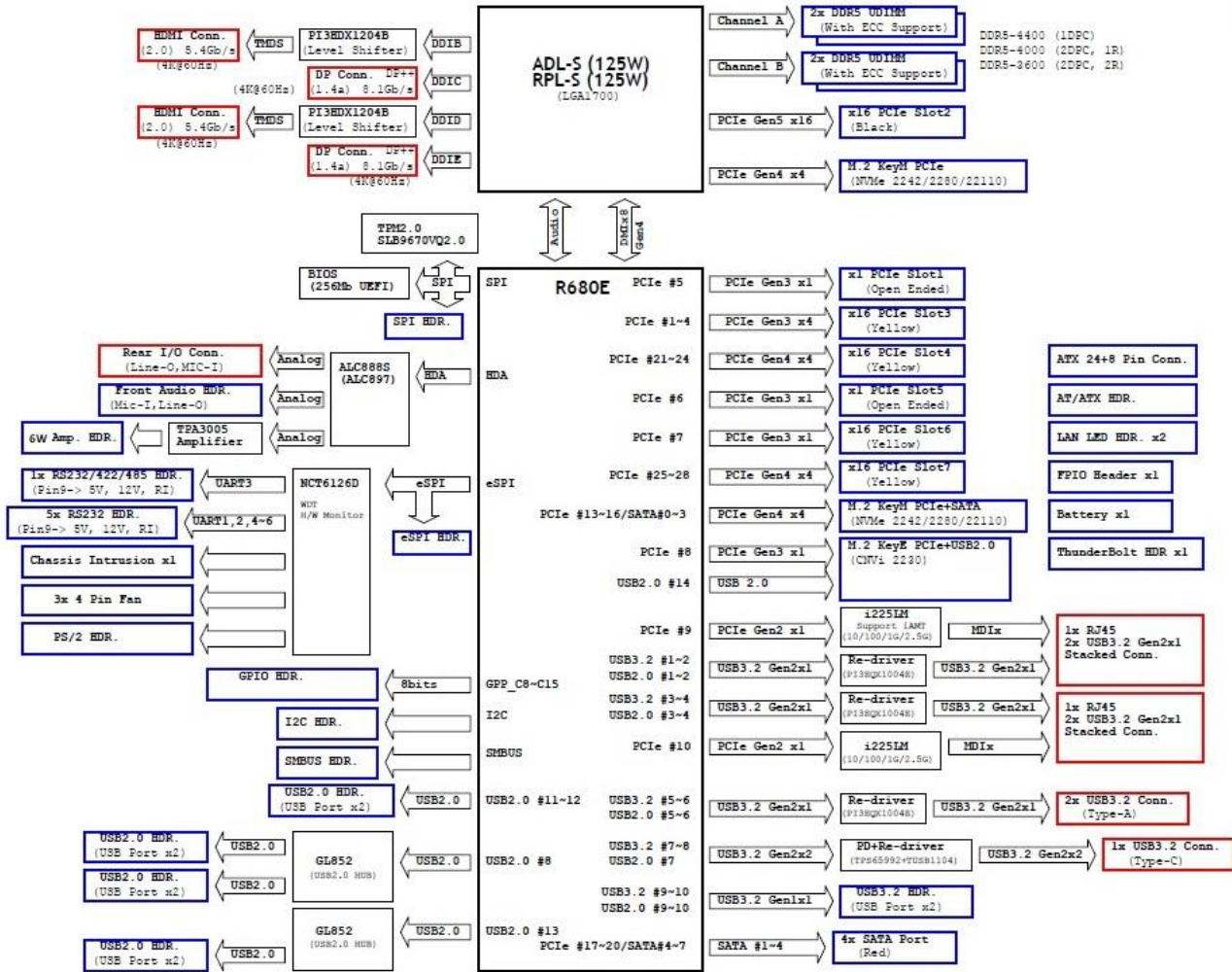

## Chapter 1 - Product Introduction

## 1.1 Before you Proceed

Take note of the following precautions before you install motherboard components or change any motherboard settings.



- Unplug the power cord from the wall socket before touching any component.
- Use a grounded wrist strap or touch a safely grounded object or a metal object, such as the power supply case, before handling components to avoid damaging them due to static electricity
- Hold components by the edges to avoid touching the ICs on them.
- Whenever you uninstall any component, place it on a grounded anti-static pad or in the bag that came with the component.
- Before you install or remove any component, ensure that the ATX power supply is switched off or the power cord is detached from the power supply. Failure to do so may cause severe damage to the motherboard, peripherals, and/or components.

## 1.2 Motherboard Overview

Before you install the motherboard, study the configuration of your chassis to ensure that the motherboard fits into it. Refer to the chassis documentation before installing the motherboard.



Make sure to unplug the power cord before installing or removing the motherboard. Failure to do so can cause you physical injury and damage motherboard components.

### 1.2.1 Placement Direction

When installing the motherboard, make sure that you place it into the chassis in the correct orientation. The edge with external ports goes to the rear part of the chassis as indicated in the image below.

### 1.2.2 Screw Holes

Place ten (10) screws into the holes indicated by circles to secure the motherboard to the chassis.



Do not over tighten the screws! Doing so can damage the motherboard.

# BC680R User's Manual

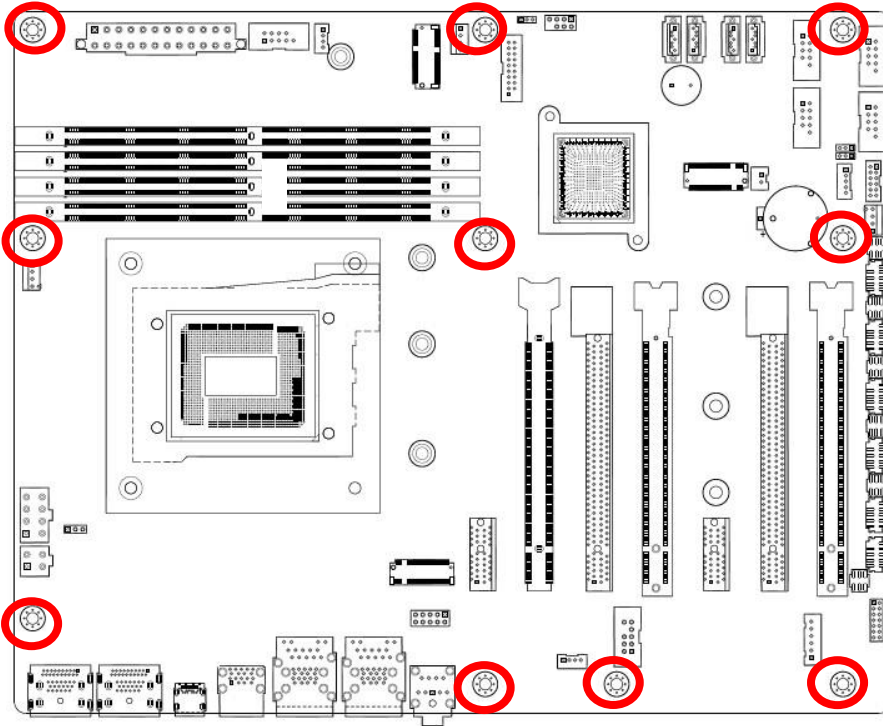

Place this side towards the rear of the chassis



### 1.2.3 Motherboard Layout

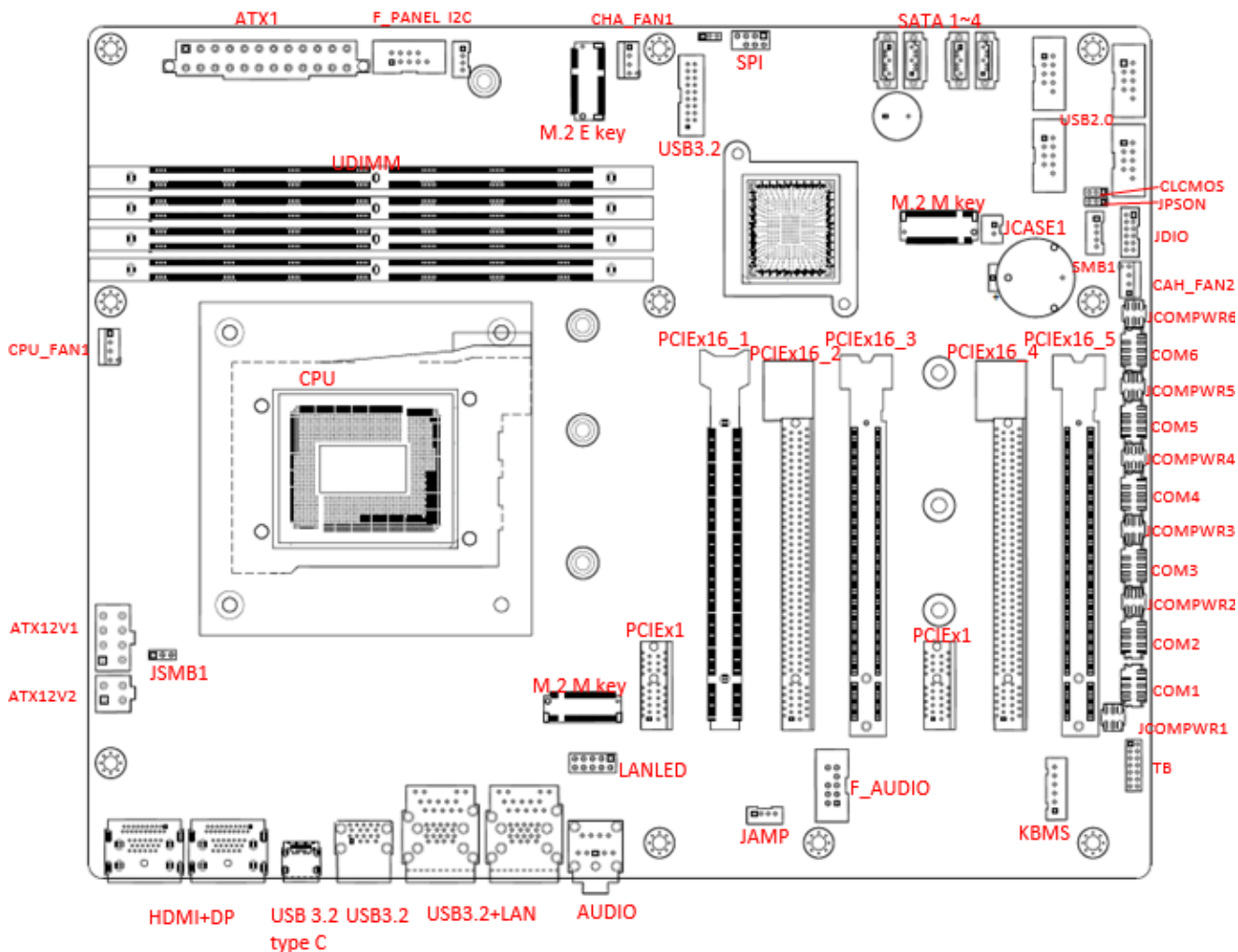

### 1.2.4 Layout Content List

Slots & socket			
Label	Function	Note	
CPU1	LGA1700 socket		
DIMMA1~B2	DDR5 UDIMM Slot	Dual channel. (2 DIMMs per channel)	
PCIEX1_1/ PCIEX1_5	PCIe x1 Gen3	X1 (Slot 1,5)	
PCIEX16_2	PCIe x16 Gen5	X16 (Slot 2)	
PCIEX16_3	PCIe x4 Gen3	X16 Physical yellow (Slot 3)	
PCIEX16_4/ PCIEX16_7	PCIe x4 Gen4	X16 Physical yellow (Slot 4,7)	
PCIEX16_6	PCIe x1 Gen3	X16 Physical yellow (Slot 6)	
Jumpers			
Label	Function	Note	

## BC680R User's Manual

CLCMOS1	Clear CMOS	1 x 3 header, pitch 2.00mm
JPSON1	AT/ATX Mode Select	1 x 3 header, pitch 2.00mm
JCOMPWR1~6	COM1~6 POWER SETTING	2 x 3 header, pitch 2.00mm

### Rear Panel Connector

Label	Function	Note
HDMI1/2	HDMI port Connector x 2	
DP1/2	Display port connector x 2	
USB56	USB 3.2 Type A Connector x 2	
USB7	USB 3.2 Type C Connector x 1	
LAN1_USB12/ LAN2_USB34	RJ-45 Ethernet Connector x 1 USB3.2 Type A Connector x 2	2.5 Gigabit Ethernet
AUDIO1	Audio phone jack	Line-out, Mic-in

### Internal Connector

Label	Function	Note
CPU_FAN1	CPU Fan connector	WAFER 1x4P, 2.54mm
CHA_FAN1	Chassis Fan connector	WAFER 1x4P, 2.54mm
CHA_FAN2	Chassis Fan connector	WAFER 1x4P, 2.54mm
F_PANEL1	Intel Front Panel connector	BOX header 2x5P, 2.54mm
ATX1	ATX power connectors	PWR Conn 2x12P
ATX12V1	12V ATX power connectors	PWR Conn 2x4P
COM1~6	Serial Port Connector	Header 2x5P, 2.00mm
SATA1~4	SATA Connector	Male connector (Red)
FP_Audio	Front Panel Audio Connector	BOX header 2x5P, 2.54mm
JDIO1	Digital I/O Connector	WAFER 6x2P, 2.0mm
I2C1	I2C connector	WAFER 4P, 2.00mm
USB89	Front USB 3.2 Header	BOX header 2x10P, 2.0mm
USB1011~USB1617	Front USB 2.0 Headers	BOX header 2x5P, 2.54mm
KBMS1	PS/2 Header	WAFER 1x5P, 2.5mm
SMB1	SMBus connector	WAFER 1x5P, 2.0mm
JAMP1	Amplifier Connector	WAFER 1x4P, 2.0mm
JCASE1	Chassis Intrusion Header	WAFER 1x2P, 2.5mm
LANLED1	LAN LED Header	Header 2x5P, 2.54mm

### 1.3 Central Processing Unit (CPU)

The motherboard comes with a surface mount LGA1700 socket designed for the Intel® Core™ i9/ i7/ i5/ i3 processor in the 1700-land package.

---

- Your boxed Intel® Core™ i9/ i7/ i5/ i3 LGA1700 processor package should come with installation instructions for the CPU, fan and heatsink assembly. If the instructions in this section do not match the CPU documentation, follow the latter.
  - Upon purchase of the motherboard, make sure that the PnP cap is on the socket and the socket pins are not bent. Contact your retailer immediately if the PnP cap is missing, or if you see any damage to the PnP cap/socket pins/motherboard components. BCM will shoulder the cost of repair only if the damage is shipment/transit-related.
  - Keep the cap after installing the motherboard. BCM will process Return Merchandise Authorization (RMA) requests only if the motherboard comes with the cap on the LGA1700 socket.
  - The product warranty does not cover damage to the socket pins resulting from incorrect CPU installation/removal, or misplacement/loss/incorrect removal of the PnP cap.
  - Install the CPU fan and heatsink assembly before you install motherboard to the chassis.
- 



If you purchased a separate CPU heatsink and fan assembly, make sure that you have properly applied Thermal Interface Material to the CPU heatsink or CPU before you install the heatsink and fan assembly.

---

## BC680R User's Manual

### 1.3.1 Installing the CPU

1. Locate the CPU socket on the motherboard.

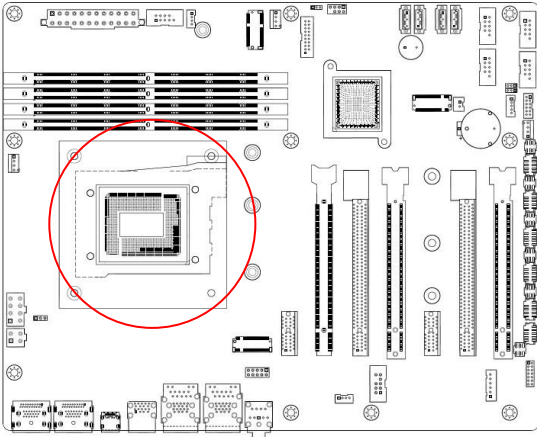

Before installing the CPU, make sure that the socket box is facing towards you and the load lever is on your left.

2. Press the load lever with your thumb (A), then move it to the left (B) until it is released from the retention tab.

**Retention tab**

**Load lever**

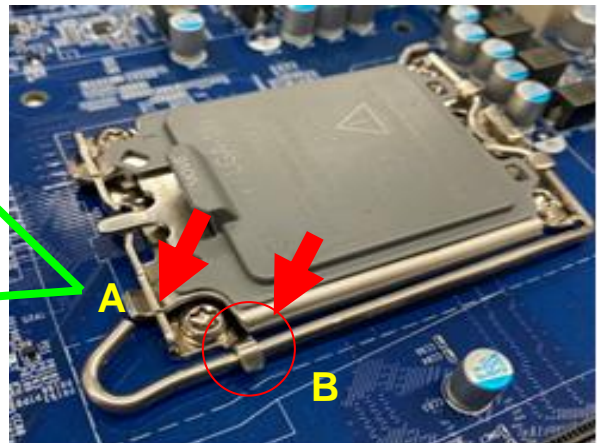

To prevent damage to the socket pins, do not remove the PnP cap unless you are installing a CPU.

3. Lift the Load lever with your thumb and forefinger to around 120° angle (C), then pull the PnP cap from the CPU socket to remove (D).





4. Position the CPU over the socket, making sure that the gold triangle is on the top-left corner of the socket then fit the socket alignment key into the CPU notch.

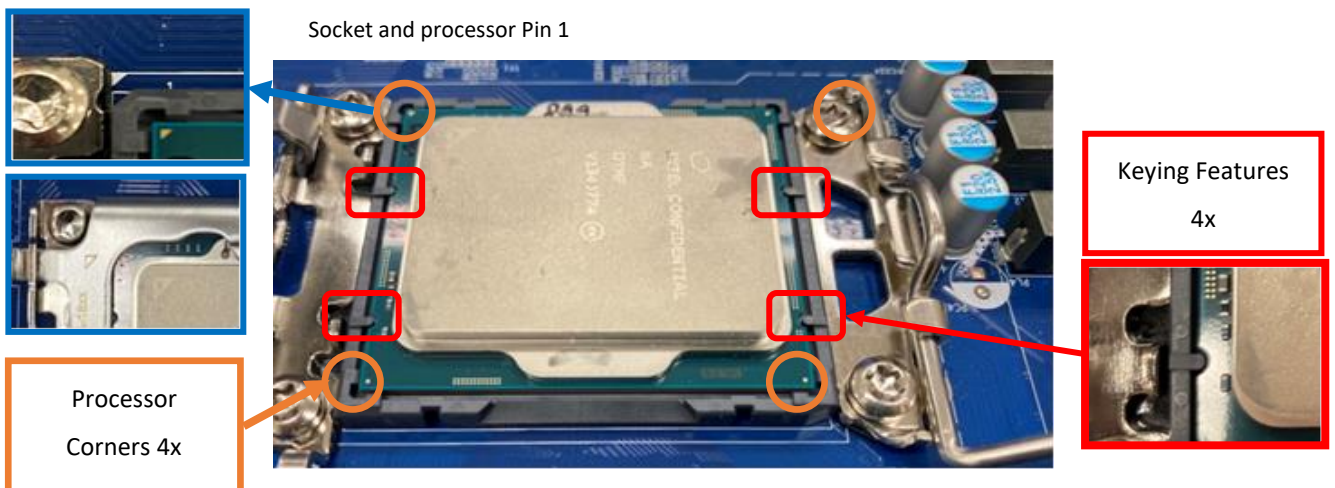

5. Pull back the load lever, then push the load lever (E) until it snaps into the retention tab.





The CPU fits in only one correct orientation. DO NOT force the CPU into the socket to prevent bending the connectors on the socket and damaging the CPU!

---

### 1.3.2 Installing the CPU Heatsink and Fan

Intel® Core™ i9/ i7/ i5/ i3 LGA1700 processor requires a specially designed heatsink and fan assembly to ensure optimum thermal condition and performance.

---



- Install the motherboard to the chassis before you install the CPU fan and heatsink assembly.
  - When you buy a boxed Intel® Core™ i9/ i7/ i5/ i3 LGA1700 processor, the package includes the CPU fan and heatsink assembly. If you buy a CPU separately, make sure that you use only Intel® certified multi-directional heatsink and fan.
  - Your Intel® Core™ i9/ i7/ i5/ i3 LGA1700 processor LGA1700 heatsink and fan assembly comes in a push-pin design and requires no tool to install.
- 



If you purchased a separate CPU heatsink and fan assembly, make sure that you have properly applied Thermal Interface Material to the CPU heatsink or CPU before you install the heatsink and fan assembly.

---

#### **To install the CPU heatsink and fan:**

1. Place the heatsink on top of the installed CPU and heatsink back plate (if need) under the CPU. Making sure that the four fasteners match the holes on the motherboard.

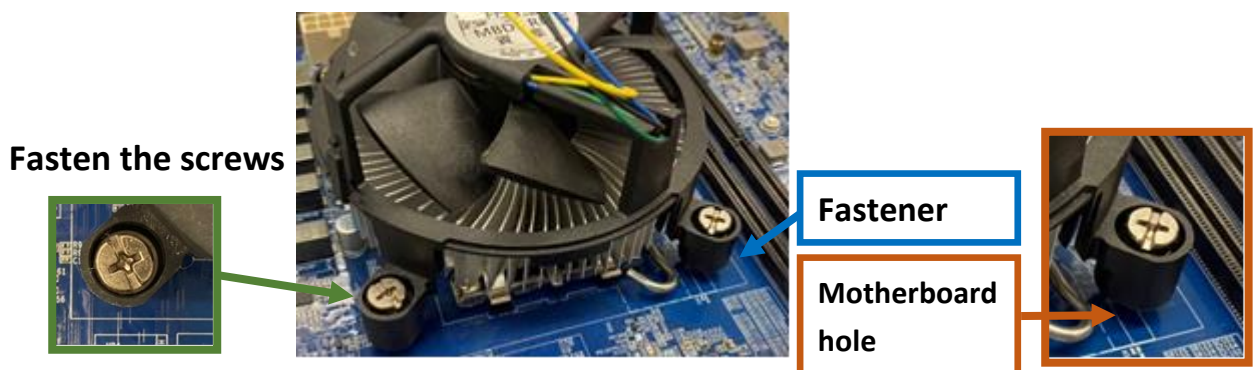

Orient the heatsink and fan assembly such that the CPU fan cable is closest to the CPU fan connector.

---



Make sure each fastener is oriented as shown.

2. Push down or fasten two fasteners at a time in a diagonal sequence to secure the heatsink and fan assembly in place.

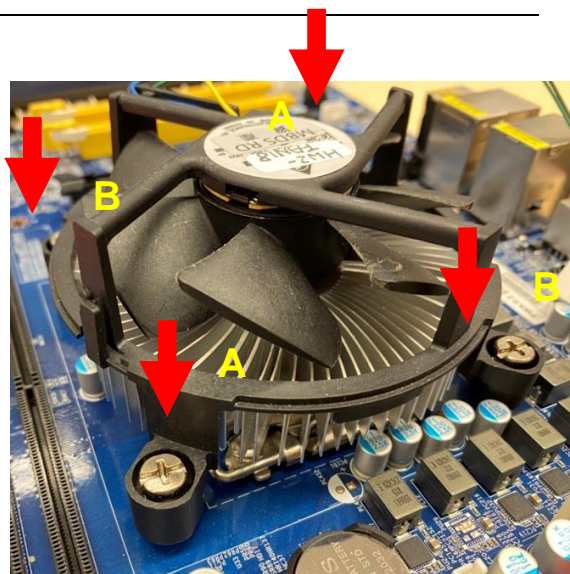
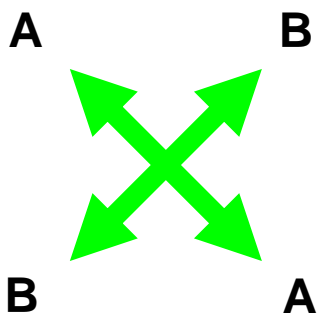

3. Connect the CPU fan cable to the connector on the motherboard labeled CPU\_FAN.

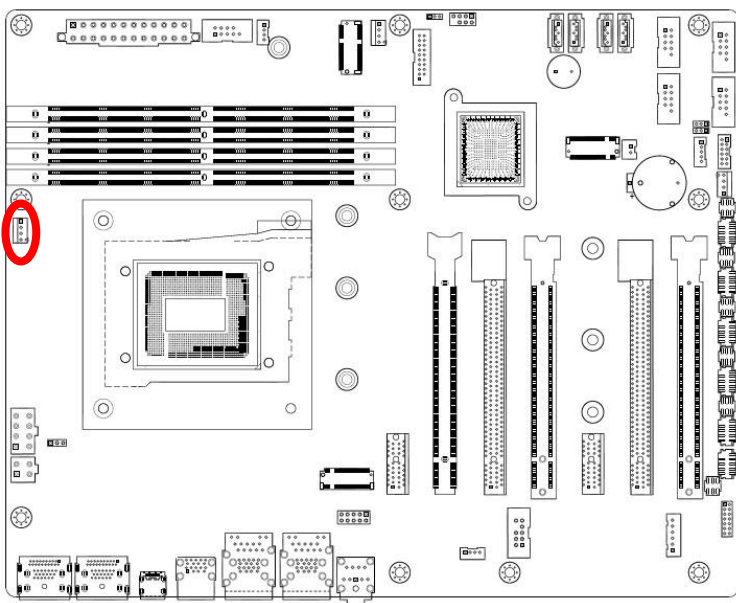

- 4. FAN\_PWM1
- 3. FAN\_SPEED2
- 2. +V12
- 1. GND



Do not forget to connect the fan cables to the fan connectors. Insufficient air flow inside the system may damage the motherboard components.

These are not jumpers! DO NOT place jumper caps on the fan connectors.

### 1.3.3 Uninstalling the CPU Heatsink and Fan

**To uninstall the CPU heatsink and fan:**



## BC680R User's Manual

1. Disconnect the CPU fan cable from the connector on the motherboard.
2. Rotate each fastener counterclockwise

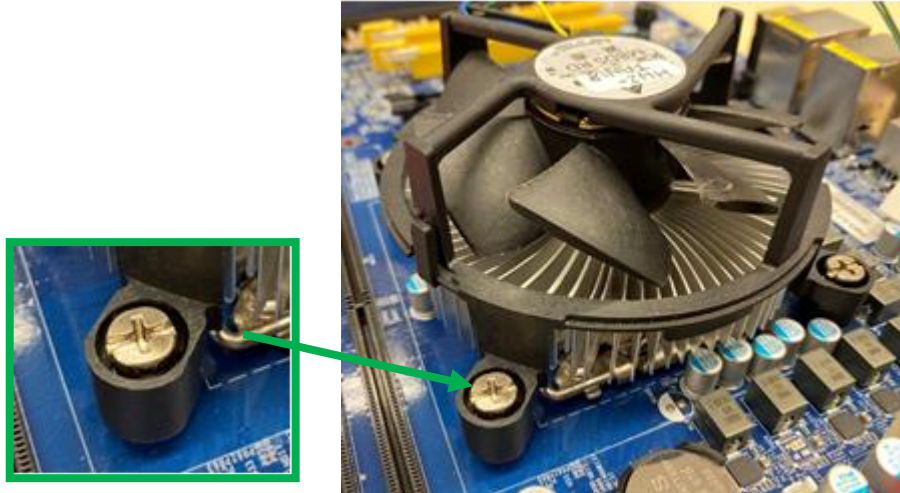

3. Pull up two fasteners at a time in a diagonal sequence to disengage the heatsink and fan assembly from the motherboard.

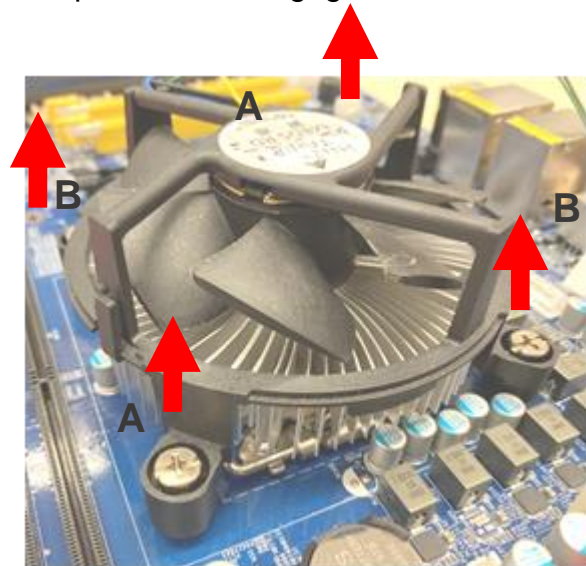
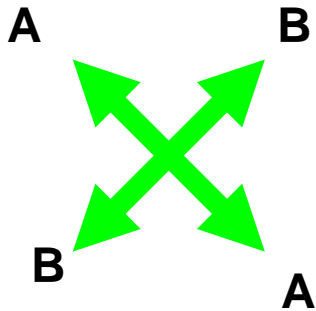

4. Carefully remove the heatsink and fan assembly from the motherboard.

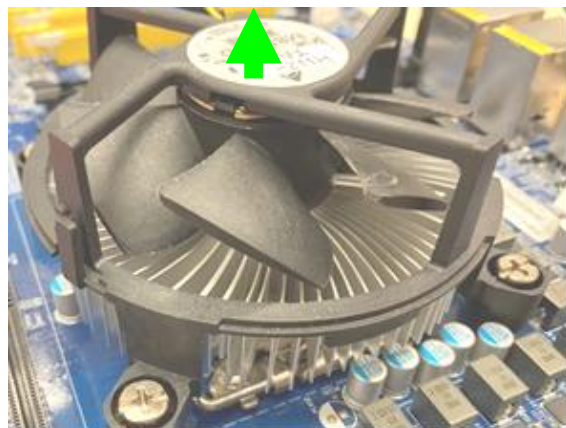



5. Rotate each fastener clockwise to ensure correct orientation when reinstalling.

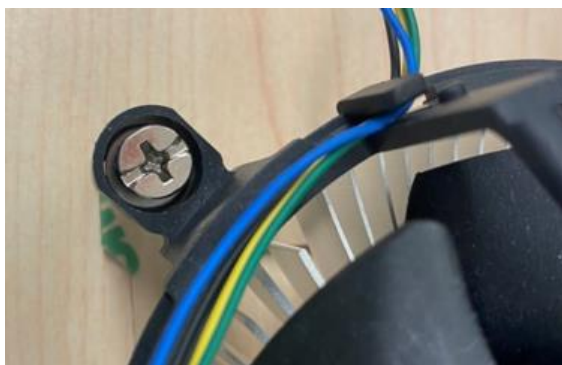

## 1.4 System Memory

### 1.4.1 Overview

The motherboard comes with two 288-pin Double Data Rate 5 (DDR5) Dual Inline Memory Modules (DIMM) sockets.

DDR5 memory brings several key performance and power gains to the table, as well as new design challenges.

From the JEDEC JESD79-5 DDR5 standard, DDR5 specification has significant improvements in capacity, speed, and voltage. Structure-wise, the Power Management IC (PMIC) is moved onto the DIMM, reducing redundant power management circuitry on the motherboard for unused DIMM slots in previous generations.

The DDR5 specification is bringing the maximum potential capacity for a single DDR5 DIMM to 128GB, a theoretical maximum transfer speed of 6400MT/s which is doubling the rate of DDR4, along with the improved power consumption as 1.1V.

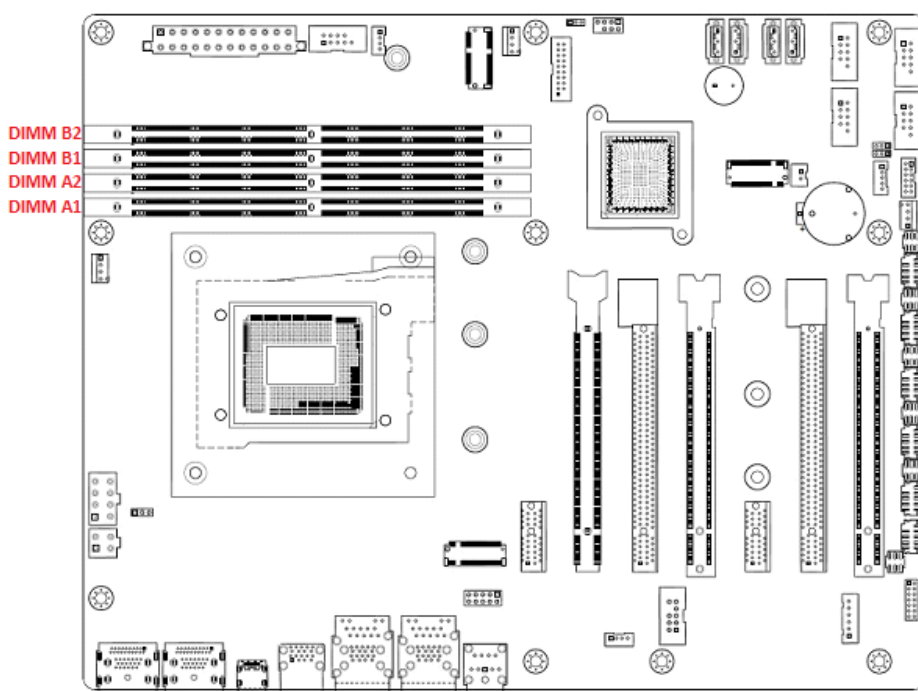

288-Pin DDR5 UDIMM sockets

### 1.4.2 Installing a DIMM



---

Make sure to unplug the power supply before adding or removing DIMMs or other system components. Failure to do so may cause severe damage to both the motherboard and the components.

---

1. Locate the DIMM socket on the board.
2. Hold two edges of the DIMM module carefully, and keep away of touching its connectors.
3. Align the notch key on the module with the rib on the slot.
4. Firmly press the modules into the socket which will automatically snap into the mounting notch. Do not force the DIMM module in with extra force as the DIMM module only fits in one direction.

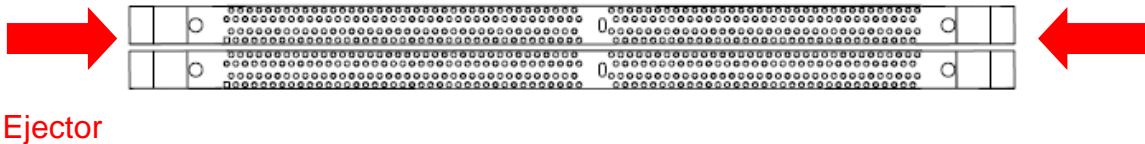

5. DDR5 DIMM module installation rule.
  - DDR5 DIMM X1 piece: DIMM B2
  - DDR5 DIMM X2 piece: DIMM A2 + DIMM B2
  - DDR5 DIMM X4 piece: DIMM A1 + DIMM A2 +DIMM B1 + DIMM B2



- 
- A DDR5 DIMM is keyed with a notch so that it fits in only one direction. DO NOT force a DIMM into a socket to avoid damaging the DIMM.
  - The DDR5 DIMM sockets do not support DDR/DDR2/DDR3/DDR4 DIMMs.
  - DO NOT install DDR/DDR2/DDR3/DDR4 DIMMs to the DDR5 DIMM socket.
- 

### 1.4.3 Removing a DDR5 DIMM

1. Press the two ejector tabs on the slot outward simultaneously, and then pull out the DIMM module.



---

Support the DIMM lightly with your fingers when pressing the ejector tabs. The DIMM might get damaged when it flips out with extra force.

---

## 1.5 Expansion Card

In the future, you may need to install expansion cards. The following sub-sections describe the slots and the expansion cards that they support.



---

Make sure to unplug the power cord before adding or removing expansion cards. Failure to do so may cause you physical injury and damage motherboard components.

---

### 1.5.1 Installing an Expansion Card

1. Before installing the expansion card, read the documentation that came with it and make the necessary hardware settings for the card.
2. Remove the system unit cover (if your motherboard is already installed in a chassis).
3. Remove the bracket opposite the slot that you intend to use. Keep the screw for later use.
4. Align the card connector with the slot and press firmly until the card is completely seated on the slot.
5. Secure the card to the chassis with the screw you removed earlier.
6. Replace the system cover.

### 1.5.2 Configuring an Expansion Card

After installing the expansion card, configure it by adjusting the software settings.

1. Turn on the system and change the necessary BIOS settings, if any. See Chapter 2 for information on BIOS setup.
2. Assign an IRQ to the card if needed.
3. Install the software drivers for the expansion card.

### 1.5.3 PCI Express x16 slot

This motherboard supports five PCI Express x16 slot that complies with the PCI Express specifications. PCIe x16 Gen5 (slot2) can only support graphic card.

# BC680R User's Manual

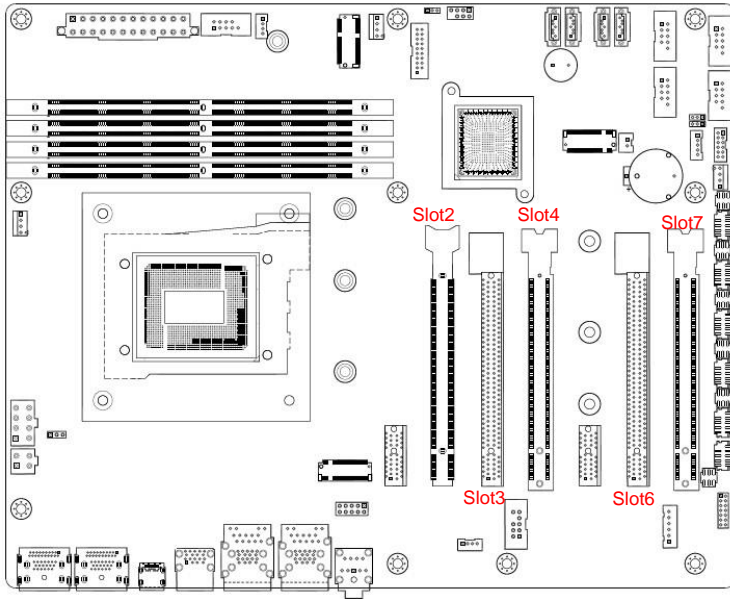

- Slot2:** Gen 5 PCIe x16 (x16 Physical Black)
- Slot3:** Gen 3 PCIe x4 (x16 Physical Yellow)
- Slot4:** Gen 4 PCIe x4 (x16 Physical Yellow)
- Slot6:** Gen 3 PCIe x1 (x16 Physical Yellow)
- Slot7:** Gen 4 PCIe x4 (x16 Physical Yellow)

## 1.5.4 PCI Express x1 slot

This motherboard supports 2 PCIe x1 slot that complies with the PCIe x1 specifications.

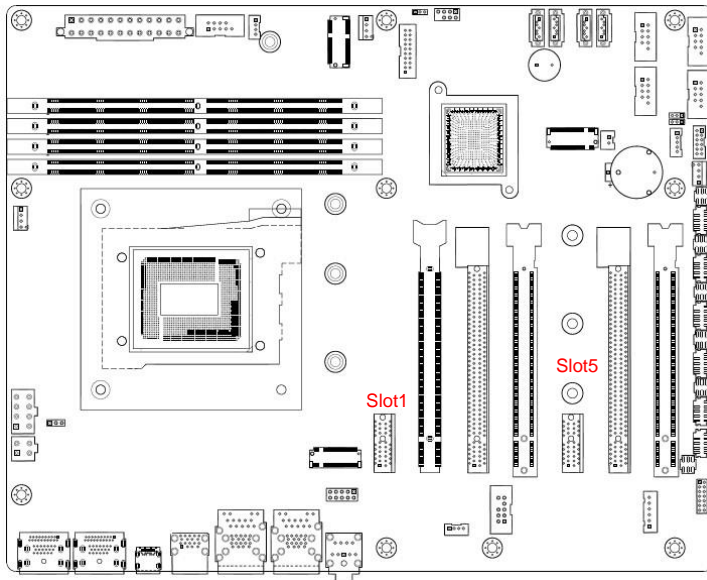

- Slot1:** Gen 3 PCIe x1 Open Ended
- Slot5:** Gen 3 PCIe x1 Open Ended

## 1.5.5 M.2 connector

Support PCIe, SATA and USB interface of this connector.

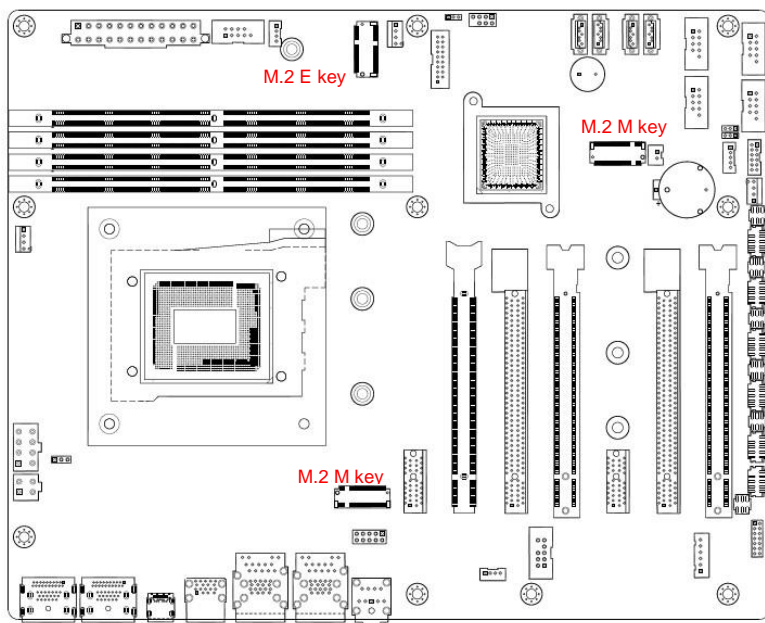

M.2 2242/2280/22110 M Key NVMe (PCIe x4 + SATA III)

M.2 2242/2280/22110 M Key NVMe (PCIe x4 Only)

1 x M.2 2230 E Key with CNVi Support (PCIe x 1 + USB 2.0)

## 1.6 Jumpers

### 1.6.1 Clear CMOS (CLCMOS1)

This jumper allows you to clear the Real Time Clock (RTC) RAM in CMOS. You can clear the CMOS memory of date, time, and system setup parameters by erasing the CMOS RTC RAM data. The onboard button cell battery powers the RAM data in CMOS, which includes system setup information such as system passwords.

To erase the RTC RAM:

1. Turn OFF the computer and unplug the power cord.
2. Remove the onboard battery.
3. Move the jumper cap from pins 1-2 (default) to pins 2-3. Keep the cap on pins 2-3 for about 5~10 seconds, then move the cap back to pins 1-2.
4. Re-install the battery.
5. Plug the power cord and turn ON the computer.
6. Hold down the <Del> key during the boot process and enter BIOS setup to re-enter data.



---

Except when clearing the RTC RAM, never remove the cap on CLRTC jumper default position. Removing the cap will cause system boot failure!

---

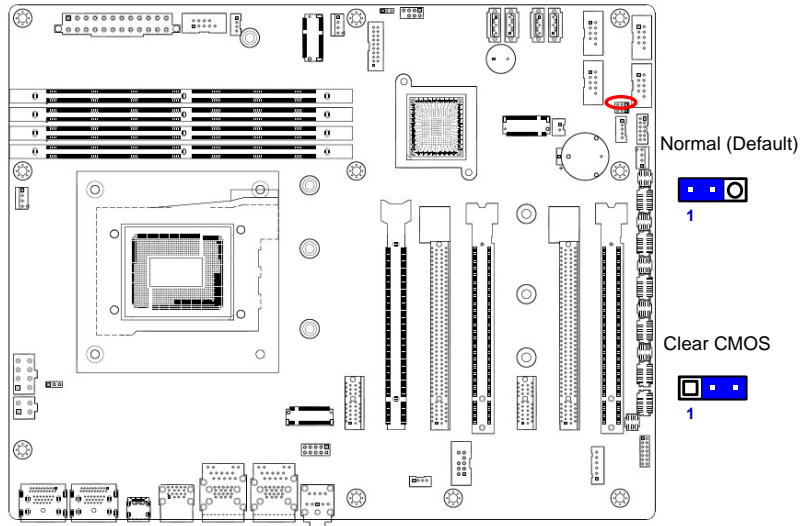

### 1.6.2 AT/ATX Power Mode Select (JPSON1)

This jumper allows you to select ATX Mode or AT mode

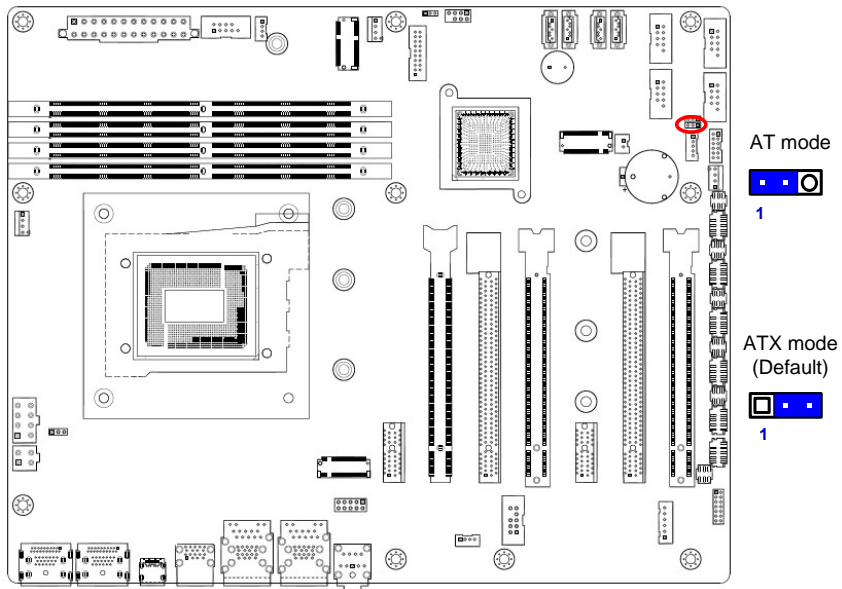



### 1.6.3 COM POWER SETTING (JCOMPWR1~6)

This jumper allows you to select COM1~6 to support Ring/+12V/+5V

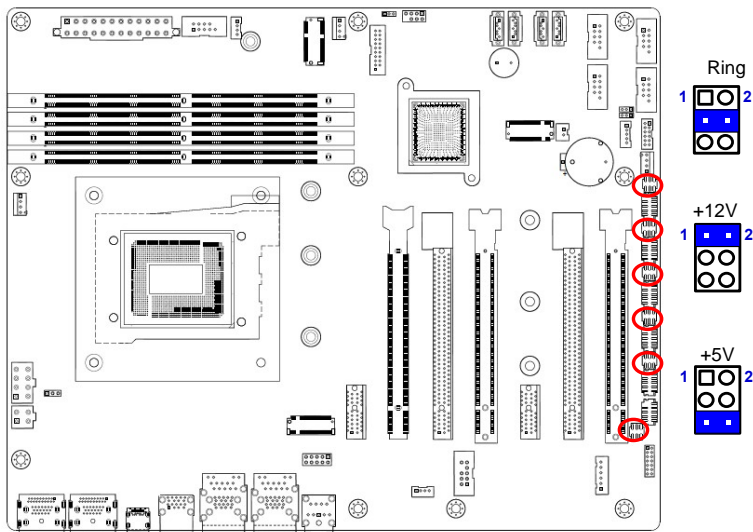

## 1.7 Connectors

### 1.7.1 Rear panel connectors

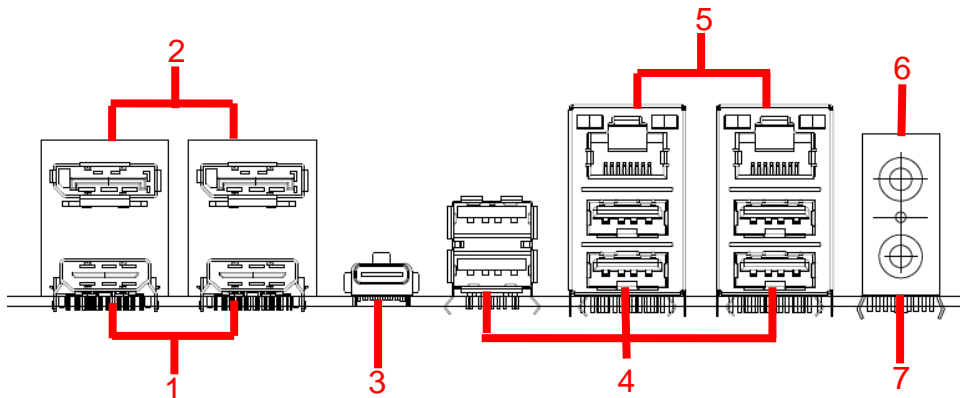

Item	Name	Function	Description
1	HDMI	HDMI Port	The HDMI port Connector
2	DP	Display Port	These two display port connectors are available for connecting display port devices.
3	USB3.2 Type C	USB 3.2 Connectors(Typ eC)	This is USB 3.2 Type-C connector
4	USB3.2 Type	USB 3.2	These six Universal Serial Bus (USB) ports are

## BC680R User's Manual

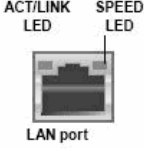
	A	Connectors(Type A)	available for connecting USB 3.2 devices.																				
5	LAN2.	2.5G LAN (RJ-45) Connectors 	This port allows 2.5G connection to a Local Area Network (LAN) through a network hub. Refer to the table below for the LAN port LED indications. <table border="1" data-bbox="734 443 1452 784"> <thead> <tr> <th colspan="2">ACT/Link LED</th> <th colspan="2">Speed LED</th> </tr> <tr> <th>Status</th> <th>Description</th> <th>Status</th> <th>Description</th> </tr> </thead> <tbody> <tr> <td>OFF</td> <td>No link</td> <td>OFF</td> <td>10/100Mbps connection</td> </tr> <tr> <td>Orange</td> <td>Linked</td> <td>Green</td> <td>1Gbps connection</td> </tr> <tr> <td>Blinking</td> <td>Data activity</td> <td>Orange</td> <td>2.5Gbps connection</td> </tr> </tbody> </table>	ACT/Link LED		Speed LED		Status	Description	Status	Description	OFF	No link	OFF	10/100Mbps connection	Orange	Linked	Green	1Gbps connection	Blinking	Data activity	Orange	2.5Gbps connection
ACT/Link LED		Speed LED																					
Status	Description	Status	Description																				
OFF	No link	OFF	10/100Mbps connection																				
Orange	Linked	Green	1Gbps connection																				
Blinking	Data activity	Orange	2.5Gbps connection																				
6	AUDIO	Line-out port (Lime)	This port connects a headphone or a speaker.																				
7	AUDIO	Microphone port (Pink)	This port connects a microphone.																				

### 1.7.2 CPU and System fan connectors (CPU\_FAN1, CHA\_FAN1, CHA\_FAN2)

The fan connectors support cooling fans of 280mA (3.36 W max.) at 4800rpm or a total of 1A~2.22A (26.64W max.) at +12V. Connect the fan cables to the fan connectors on the motherboard, making sure that the black wire of each cable matches the ground pin of the connector.

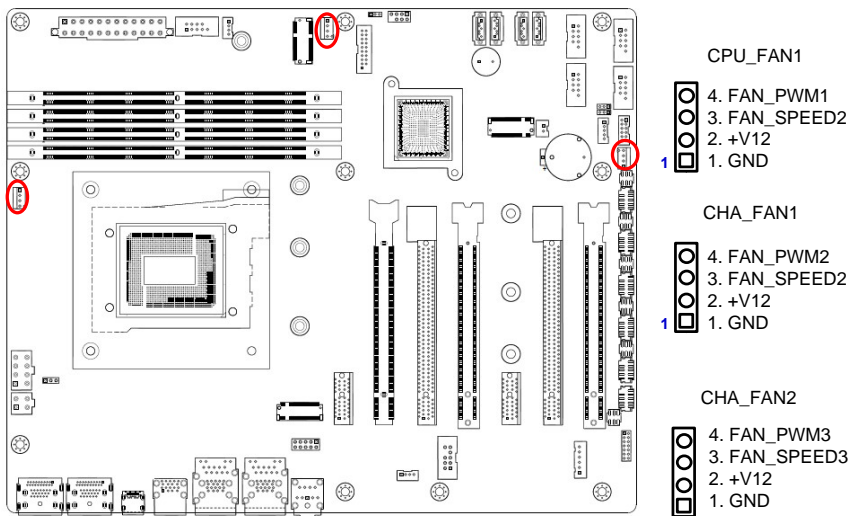





Do not forget to connect the fan cables to the fan connectors. Insufficient air flow inside the system may damage the motherboard components. These are not jumpers! DO NOT place jumper caps on the fan connectors.

### 1.7.3 System Panel (F\_PANEL)

This connector is for a chassis-mounted front panel. The functions are as following.

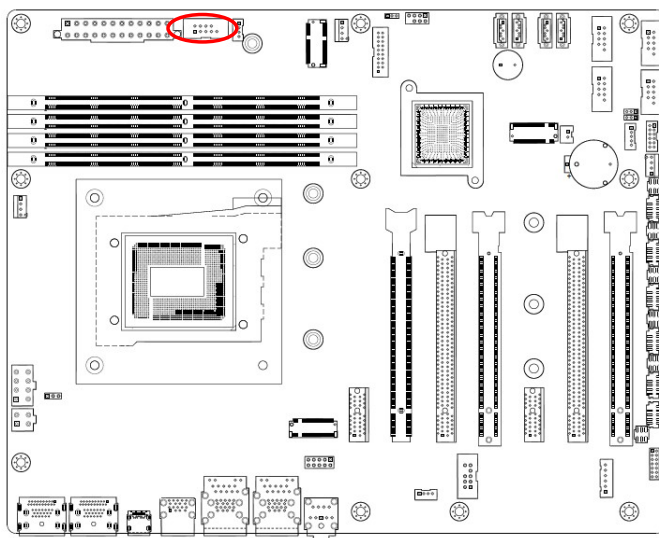

- |             |             |
|-------------|-------------|
| 1. HDD LED+ | 2. +5VSB    |
| 3. HDD LED# | 4. PWR LED# |
| 5. GND      | 6. PANSWIN# |
| 7. RST      | 8. GND      |
| 9. N/A      |             |

- **ATX Power Button/Soft-off Button (Pin 6-8)**

This 2-pin connector is for the system power button. Pressing the power button turns the system on or puts the system in sleep or soft-off mode depending on the BIOS settings. Pressing the power switch and holding it for more than four seconds while the system is ON turns the system OFF.

- **Reset Button (Pin 5-7)**

This 2-pin connector is for the chassis-mounted reset button for system reboot without turning off the system power.

- **Power LED (Pin 2-4)**

This 2-pin connector is for the system power LED. Connect the chassis power LED cable to this connector. The system power LED lights up when you turn on the system power, and blinks when the system is in sleep mode.

- **Hard Disk Drive Activity LED (Pin 1-3)**

This 2-pin connector is for the HDD Activity LED. Connect the HDD Activity LED cable to this connector. The IDE LED lights up or flashes when data is read from or written to the HDD.

## BC680R User's Manual

### 1.7.4 ATX power connectors (ATX1 & ATX12V1)

The connector is for ATX power supply plugs. The power supply plugs are designed to fit these connectors in only one orientation. Find the proper orientation and push down firmly until the connectors completely fit.

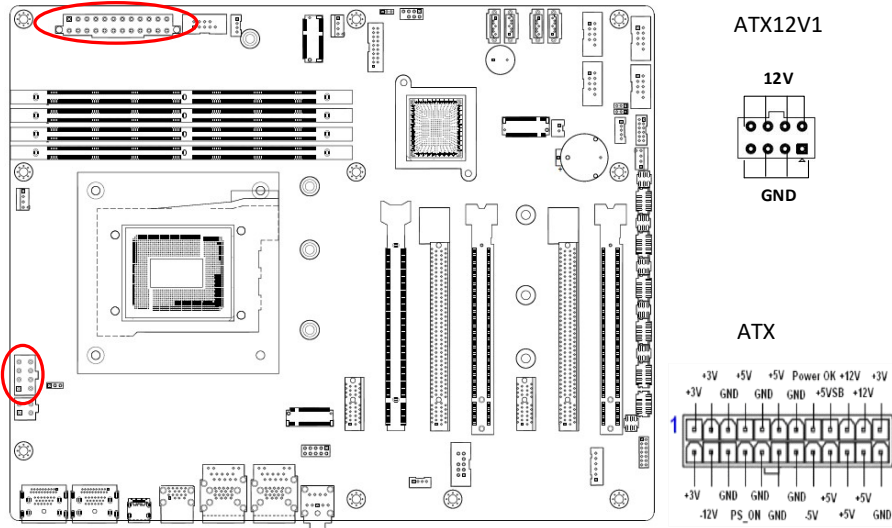

- Use of a PSU with a higher power output is recommended when configuring a system with more power-consuming devices. The system may become unstable or may not boot up if the power is inadequate.
- Make sure that your power supply unit (PSU) can provide at least the minimum power required by your system. See the table below for details.

### 1.7.5 Serial Port connectors (COM1~6)

This connector is for a serial (COM) port. Connect the serial port module cable to this connector, then install the module to a slot opening at the back of the system chassis.

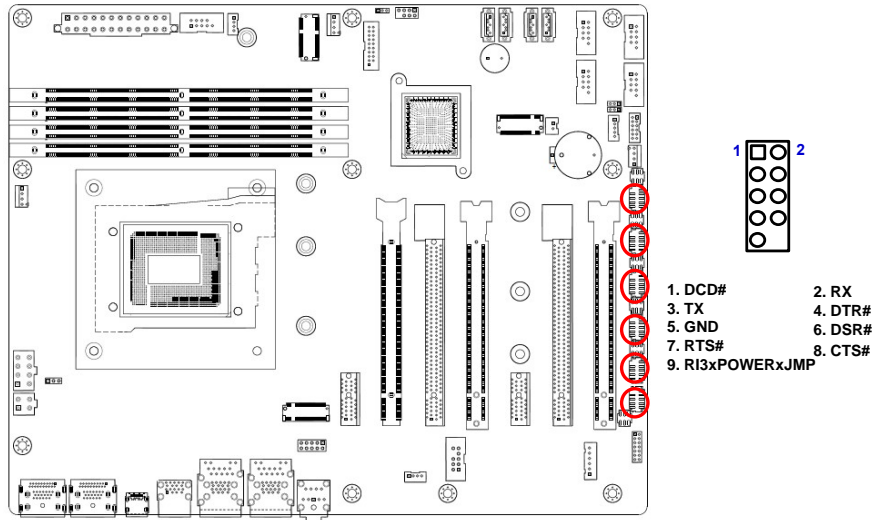

### 1.7.6 Serial ATA Connector (SATA1~4 )

SATA 1~4 support SATA III. These connectors are suitable for the SATA signal cables and connect to Serial ATA devices.

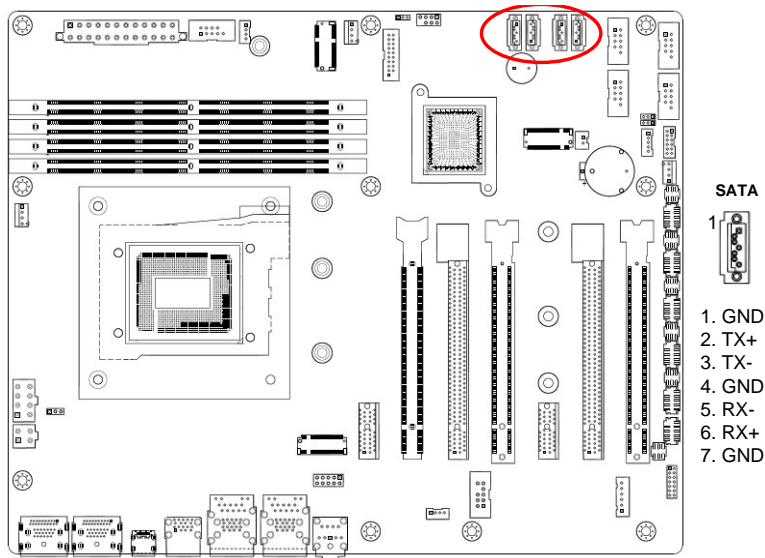

### 1.7.7 USB connectors (USB1011, USB1213, USB1415, USB1617)

These connectors are for USB 2.0 ports. Connect the optional USB module cable to any of these connectors, then install the module to a slot opening at the back of the system chassis. These USB connectors comply with USB 2.0 specification that supports up to 480 Mbps

# BC680R User's Manual

connection speed.

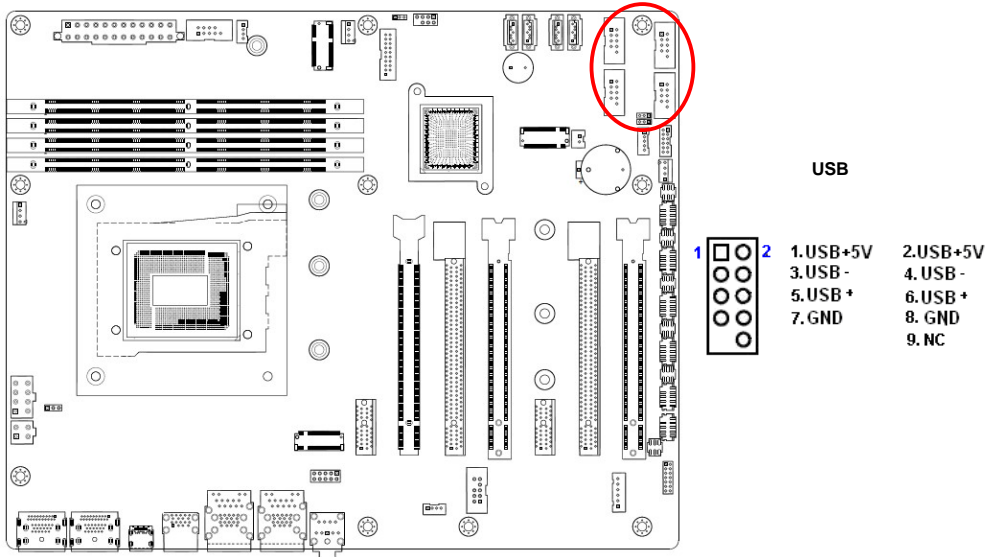

	Never connect a <b>1394 cable</b> to the USB connectors. Doing so will damage the motherboard!
	The USB module is purchased separately.

## 1.7.8 USB3.2 connector (USB89)

This connector provides 2 USB3.2 Gen1 ports. Connect the optional USB module cable to any of these connectors, then install the module to a slot opening at the back of the system chassis. These USB connectors comply with USB3.2 specification that supports up to 5Gbps connection speed.

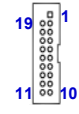
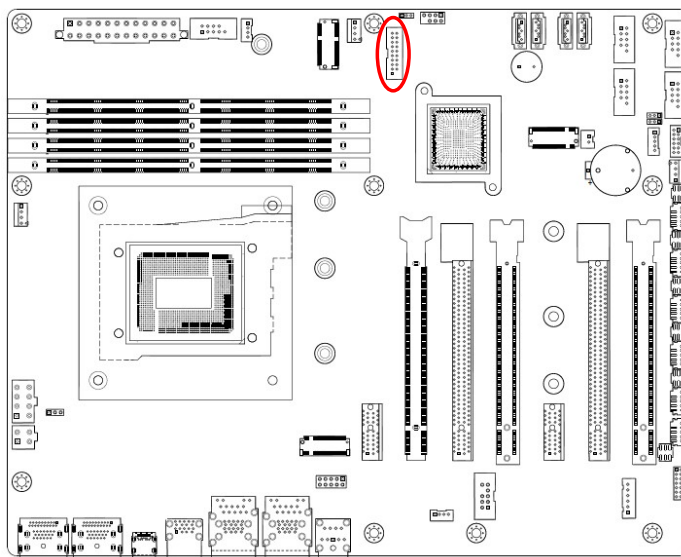

- 1. +5V
- 2. USB3\_RX-
- 3. USB3\_RX+
- 4. GND
- 5. USB3\_TX-
- 6. USB3\_TX+
- 7. GND
- 8. USB-
- 9. USB+
- 10. NC
- 11. USB+
- 12. USB-
- 13. GND
- 14. USB3\_TX+
- 15. USB3\_TX-
- 16. GND
- 17. USB3\_RX+
- 18. USB3\_RX-
- 19. +5V

### 1.7.9 8 bit GPIO header (JDIO1)

This connector provides a 8 bits input or output for general purpose.

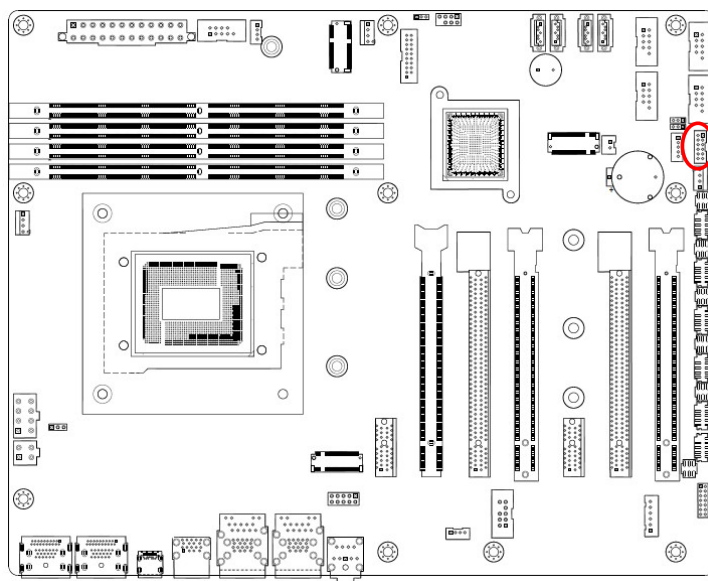

- 1. SIO\_GPIO0
- 2. SIO\_GPIO4
- 3. SIO\_GPIO1
- 4. SIO\_GPIO5
- 5. SIO\_GPIO2
- 6. SIO\_GPIO6
- 7. SIO\_GPIO3
- 8. SIO\_GPIO7
- 9. SMB\_CLK\_
- 10. SMB\_DATA\_
- RESUME
- 11. GND
- 12. +5Vsb

# BC680R User's Manual

## 1.7.10 Front Audio connector (FP\_AUDIO1)

This connector is for a chassis-mounted front panel audio I/O module that supports either HD Audio or legacy AC '97 (optional) audio standard.

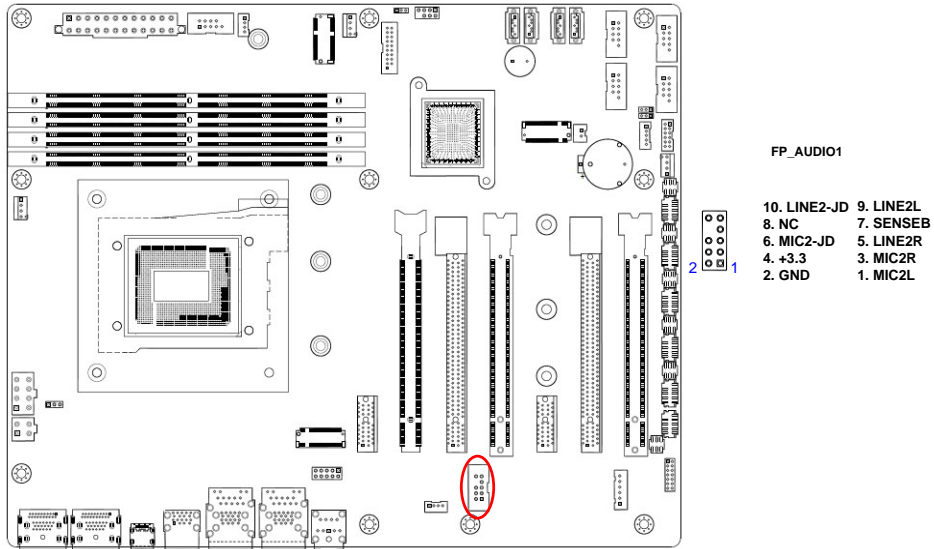

## 1.7.11 Amplifier Connector (JAMP1)

This connector allow user to connect an external audio amplifier.

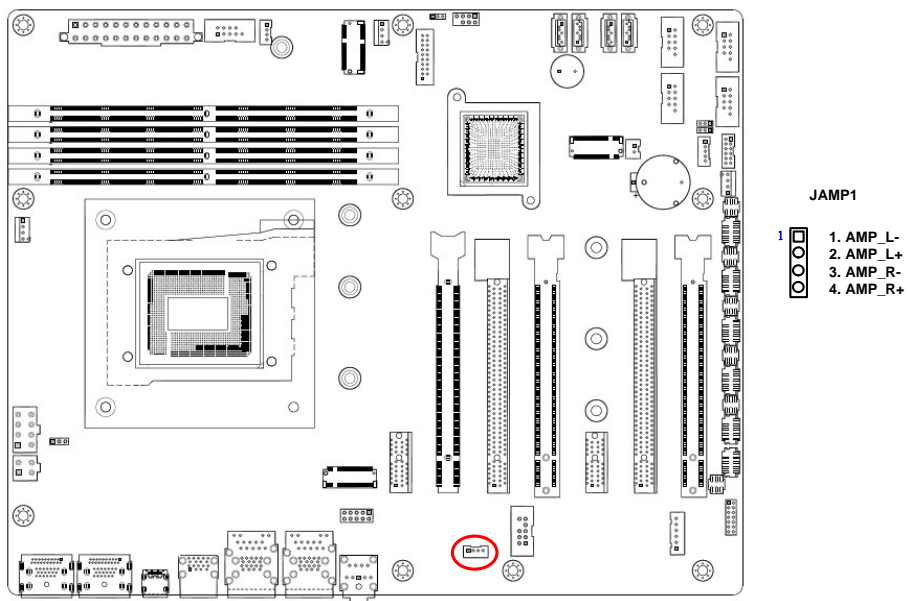



### 1.7.12 SM bus connector (SMB1)

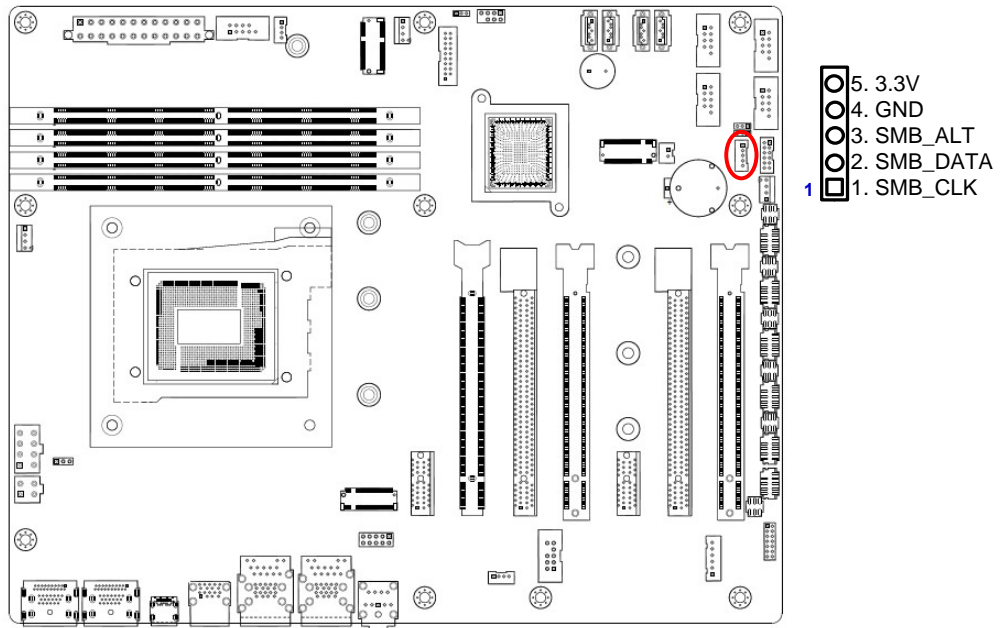

### 1.7.13 LAN LED status connector (LANLED1)

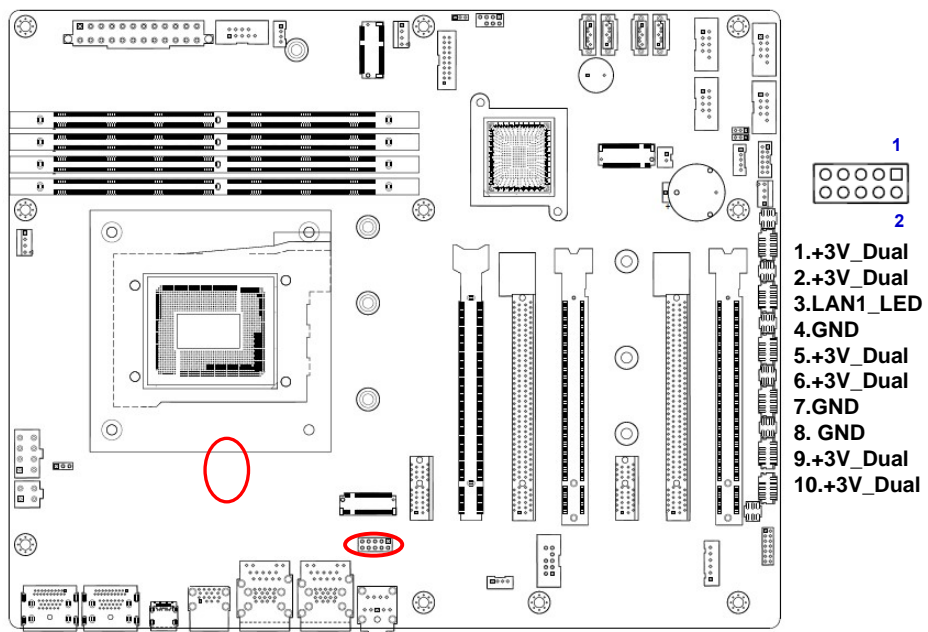

# BC680R User's Manual

## 1.7.14 Chassis intrusion connector (JCASE1)

This connector allow user to connect a sensor in system case. Once the chassis is opened, system will alert user or administrator.

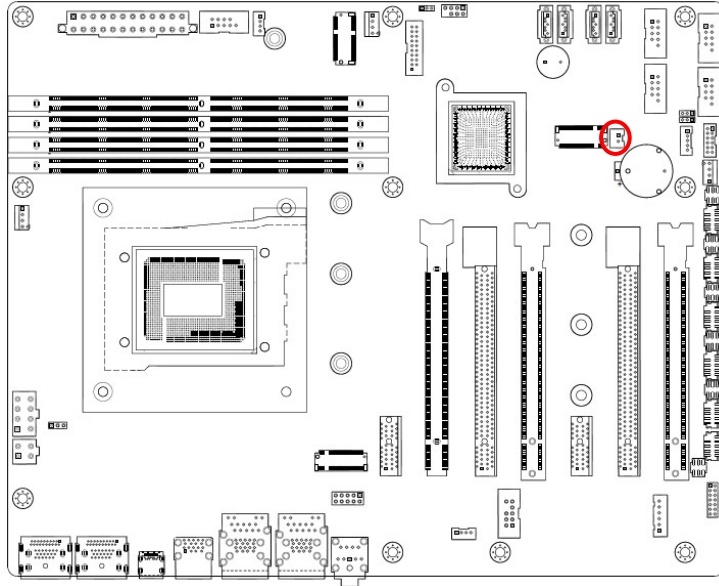

- 1. SIO\_CASEOPEN#
- 2. GND



This chapter tells how to change the system settings through the BIOS Setup menus. Detailed descriptions of the BIOS parameters are also provided.

# 2

## **BIOS Setup**

## Chapter 2 - BIOS Setup

### 2.1 BIOS Setup Program

This motherboard supports a programmable firmware chip that you can update using the provided utility. Use the BIOS Setup program when you are installing a motherboard, reconfiguring your system, or prompted to "Run Setup." This section explains how to configure your system using this utility.

Even if you are not prompted to use the Setup program, you can change the configuration of your computer in the future. For example, you can enable the security password feature or change the power management settings. This requires you to reconfigure your system using the BIOS Setup program so that the computer can recognize these changes and record them in the CMOS RAM of the firmware hub.

The firmware hub on the motherboard stores the Setup utility. When you start up the computer, the system provides you with the opportunity to run this program. Press <Del> during the Power-On-Self-Test (POST) to enter the Setup utility; otherwise, POST continues with its test routines.

If you wish to enter Setup after POST, restart the system by pressing <Ctrl+Alt+Delete>, or by pressing the reset button on the system chassis. You can also restart by turning the system off and then back on. Do this last option only if the first two failed.

The Setup program is designed to make it as easy to use as possible. Being a menu-driven program, it lets you scroll through the various sub-menus and make your selections from the available options using the navigation keys.



- The default BIOS settings for this motherboard apply for most conditions to ensure optimum performance. If the system becomes unstable after changing any BIOS settings, load the default settings to ensure system compatibility and stability. Select the **Load Optimized Defaults** from the BIOS menu screen.
- The BIOS setup screens shown in this section are for reference purposes only, and may not exactly match what you see on your screen.
- Visit the system builder's website to download the latest BIOS file for this motherboard

### 2.1.1 Legend Box

The keys in the legend bar allow you to navigate through the various setup menus

Key(s)	Function Description
→←	Select Screen
↑↓	Select Item
Enter	Select
+ -	Change Opt.
F1	General Help
F2	Previous Values
F3	Optimal Defaults
F4	Save and Exit
ESC	Exit

### 2.1.2 List Box

This box appears only in the opening screen. The box displays an initial list of configurable items in the menu you selected.

### 2.1.3 Sub-menu

Note that a right pointer symbol  appears to the left of certain fields. This pointer indicates that you can display a sub-menu from this field. A sub-menu contains additional options for a field parameter. To display a sub-menu, move the highlight to the field and press <Enter>. The sub-menu appears. Use the legend keys to enter values and move from field to field within a sub-menu as you would within a menu. Use the <Esc> key to return to the main menu.

Take some time to familiarize yourself with the legend keys and their corresponding functions. Practice navigating through the various menus and submenus. If you accidentally make unwanted changes to any of the fields, press <F3> to load the optimal default values. While moving around through the Setup program, note that explanations appear in the Item Specific Help window located to the right of each menu. This window displays the help text for the currently highlighted field.

## 2.2 BIOS Menu Screen

When you enter the BIOS, the following screen appears. The BIOS menu screen displays the items that allow you to make changes to the system configuration. To access the menu items, press the up/down/right/left arrow key on the keyboard until the desired item is highlighted, then press [Enter] to open the specific menu.

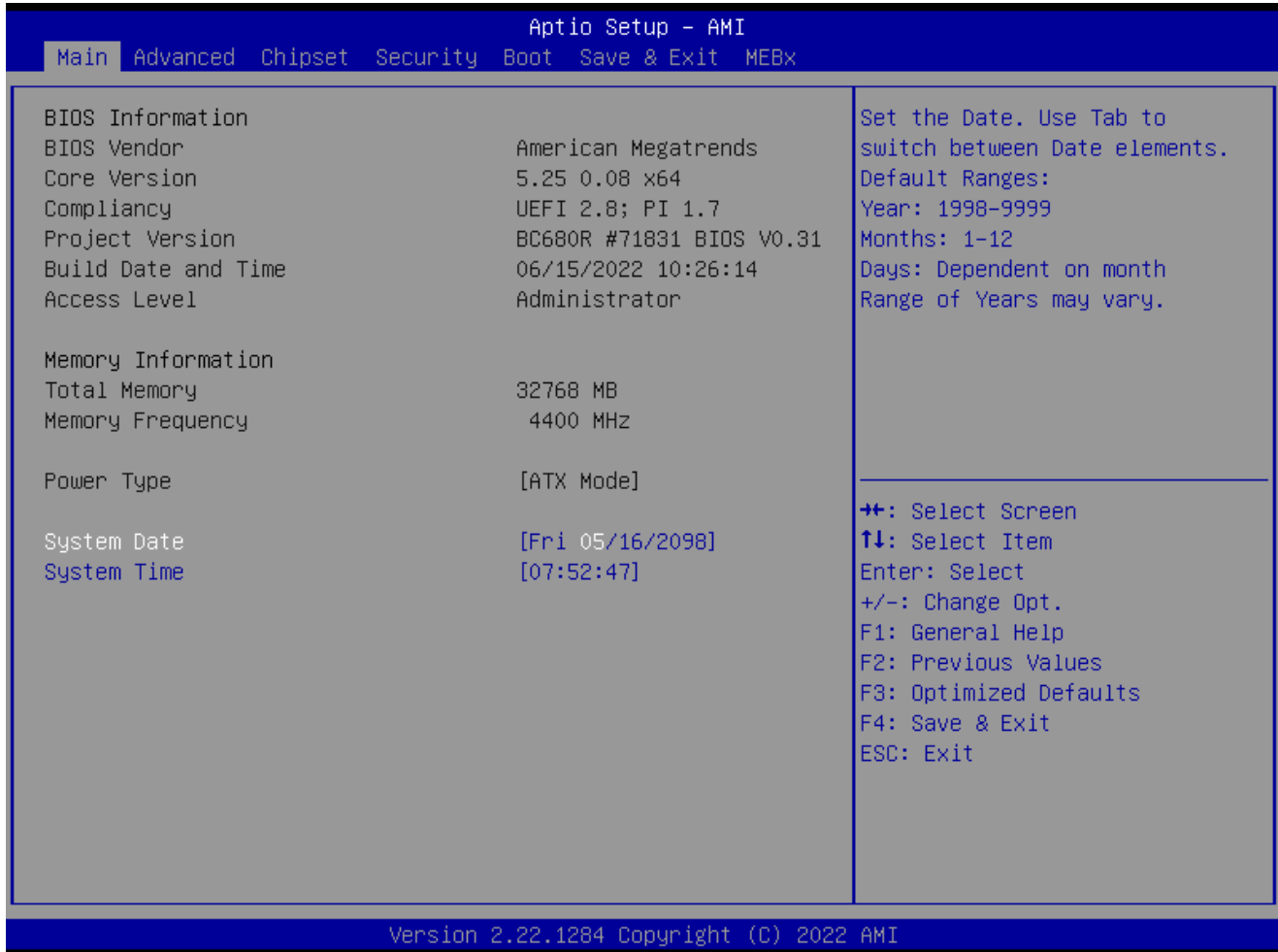

## 2.3 Main Setup

This menu gives you an overview of the general system specifications. The BIOS automatically detects the items in this menu. Use this menu for basic system configurations, such as time, date etc.



### BIOS Information

Displays the auto-detected BIOS information.

- **System Date**

The date format is <Date>,<Month>,<Day>,<Year>.

- **System Time**

The time format is <Hour>,<Minute>,<Second>.

## 2.4 Advanced BIOS Setup

Select the Advanced tab from the setup screen to enter the Advanced BIOS Setup screen. You can select any of the items in the left frame of the screen, such as Chipset configuration, to go to the sub menu for that item. You can display an Advanced BIOS Setup option by highlighting it using the <Arrow> keys. All Advanced BIOS Setup options are described in this section. The Advanced BIOS Setup screen is shown below. The sub menus are described on the following pages.

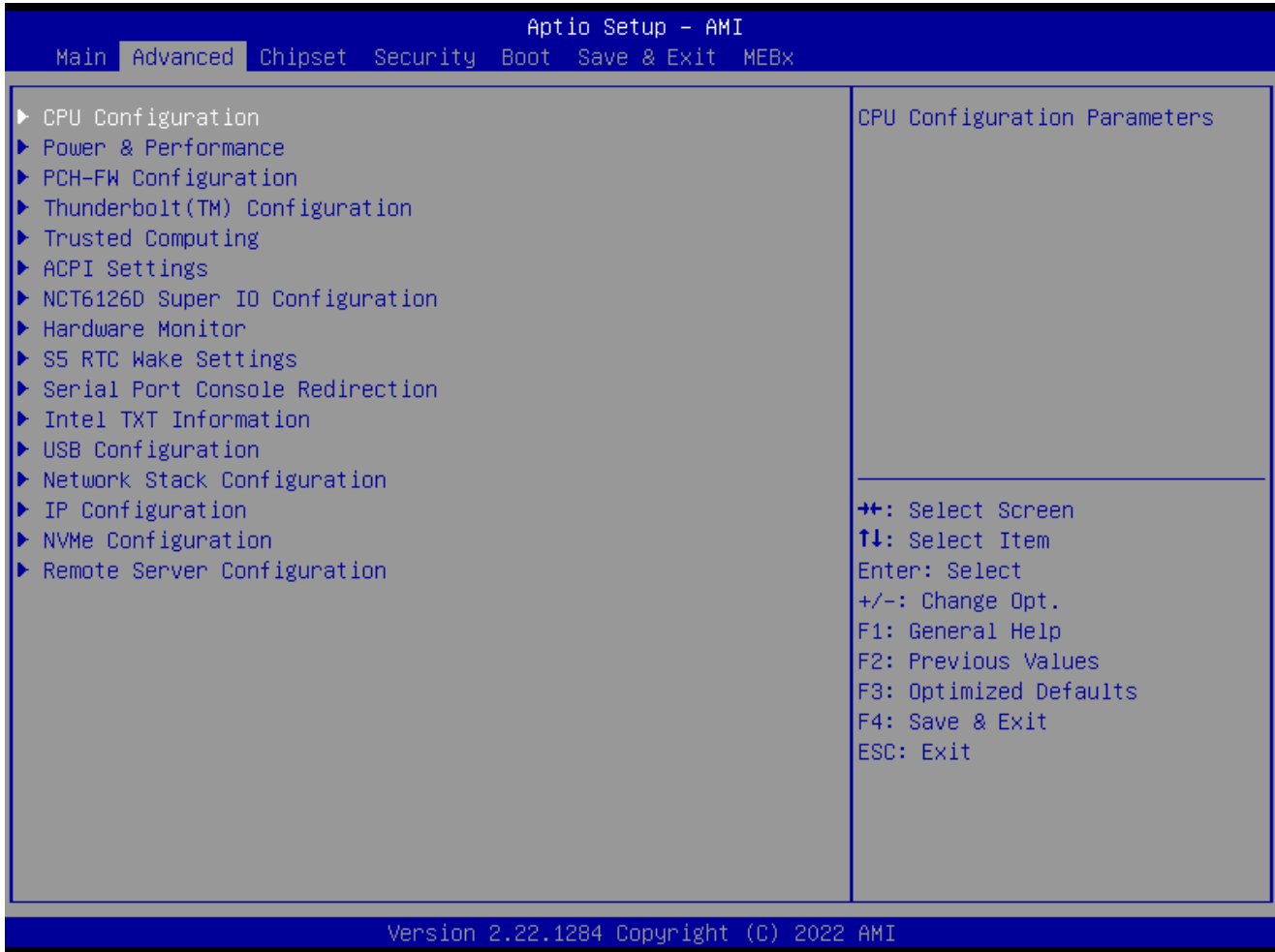

Take caution when changing the settings of the Advanced menu items. Incorrect field values can cause the system to malfunction.

## 2.4.1 CPU Configuration

Display CPU information and related setting

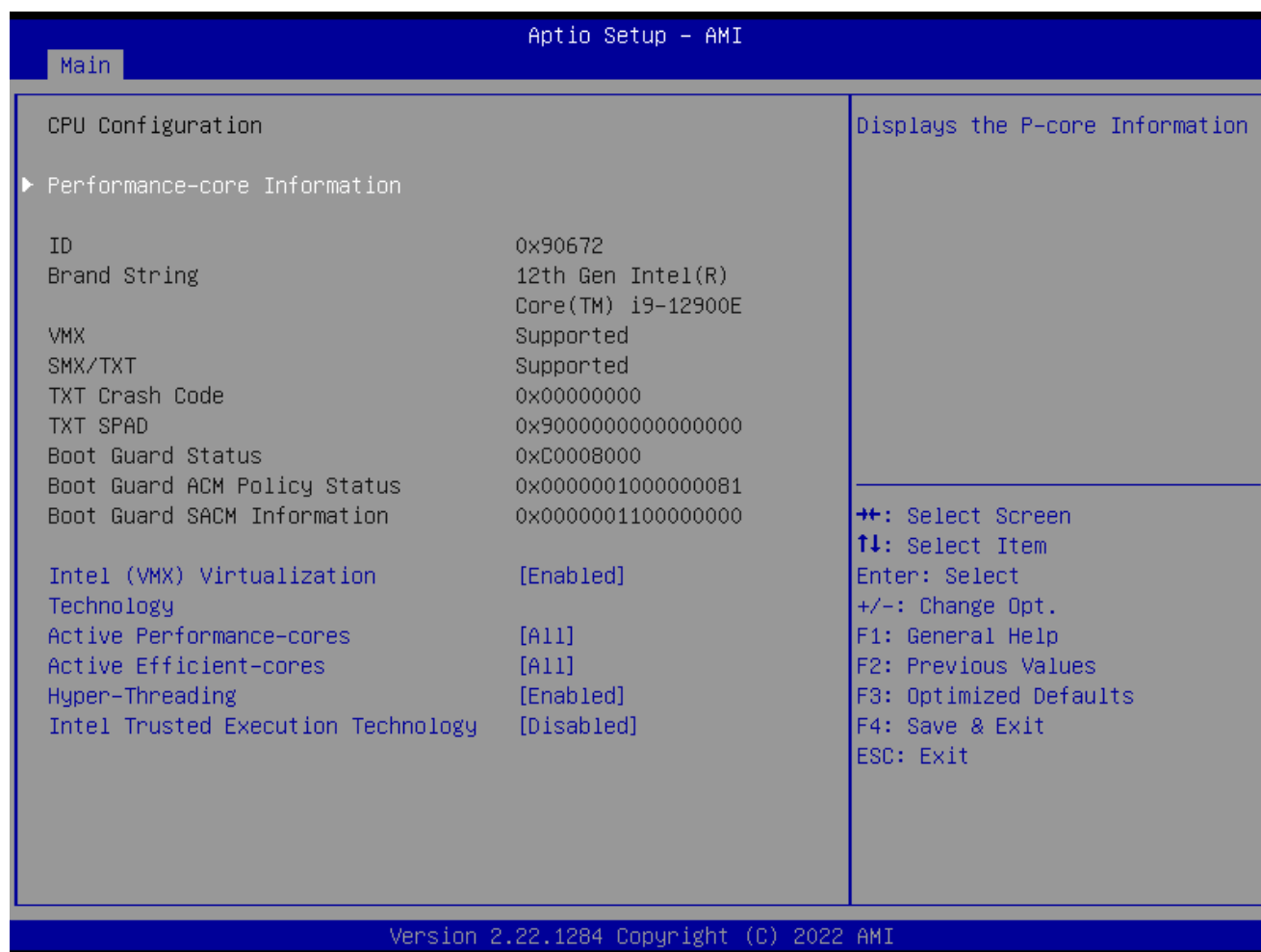

- **Intel(VMX)Virtualization[Enabled]**  
When enabled, a VMX can utilize the additional hardware compatibilities provided by Vanderpool Technology  
Configuration options: [Enable] [Disable]
- **Active Performance –Cores**  
Number of P-core to enable in each processor package
- **Active Efficient-cores**  
Number of E-core to enable in each processor package
- **Hyper-Threading**  
Enable or disable Hyper-Threading technology  
Configuration options: [Enable] [Disable]
- **Intel Trusted Execution Technology**  
Enabled utilization of additional hardware capabilities provided by Intel Trusted execution technology  
Configuration options: [Enable] [Disable]

# BC680R User's Manual

## 2.4.2 Power & Performance

### Power management control for CPU

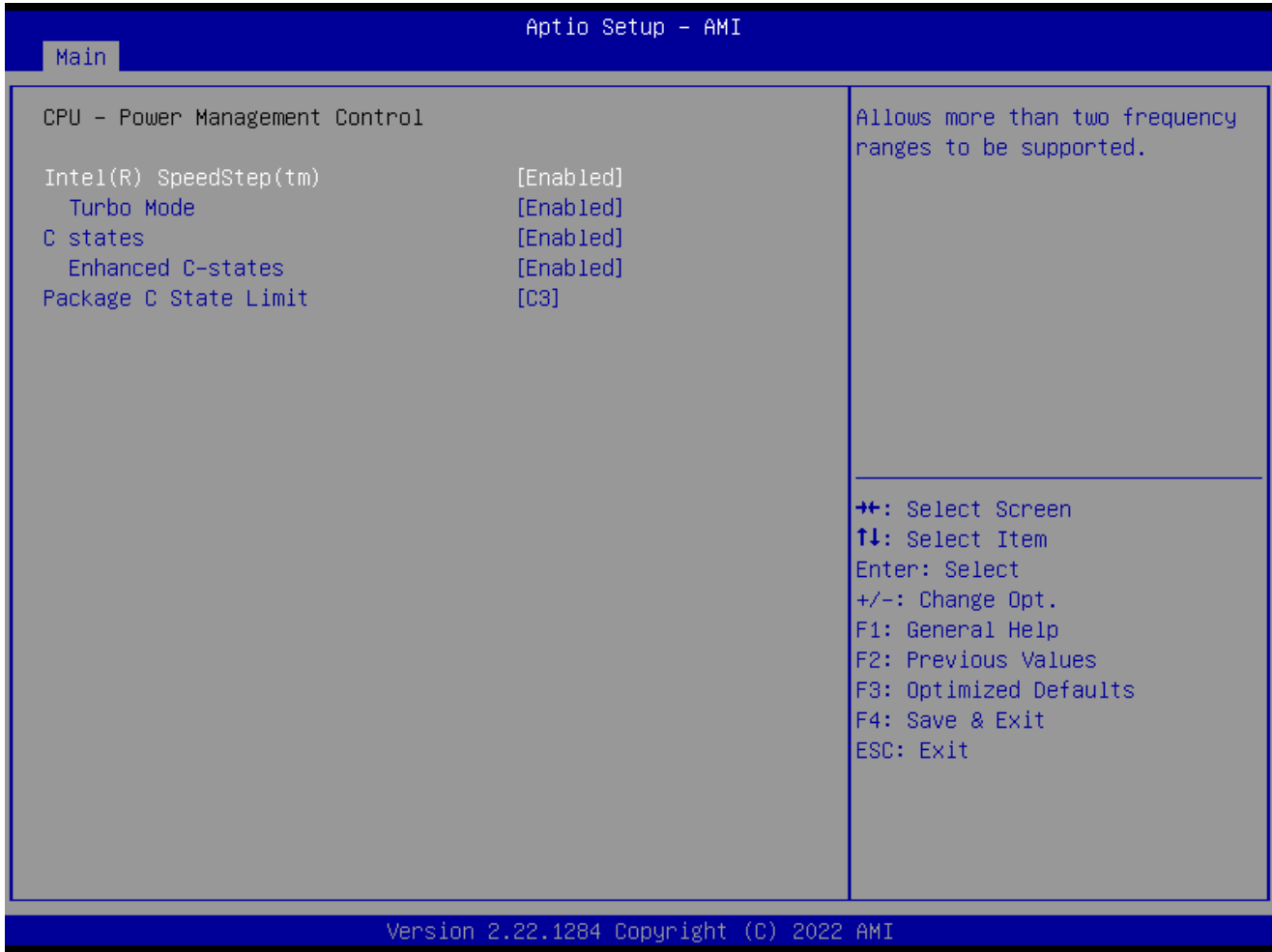

- **Intel® Speedstep™ [Enabled]**  
Allow more than two frequency range to be supported  
Configuration options: [Enable] [Disable]
- **Turbo Mode**  
Enable or Disable processor Turbo mode  
Configuration options: [Enable] [Disable]
- **C states**  
Enable/Disable CPU power management. Allows CPU to go to C states when it's not 100% utilized  
Configuration options: [Enable] [Disable]
- **Enhance C states**  
When enabled, CPU will switch to minimum speed when all cores enter C state  
Configuration options: [Enable] [Disable]
- **Package C state limit**  
Maximum package C state limit setting. CPU default : Leaves to factory default value  
Configuration options: [C0/C1] [C2] [C3]



### 2.4.3 PCH-FW configuration

#### Configure Management Engine Technology Parameters

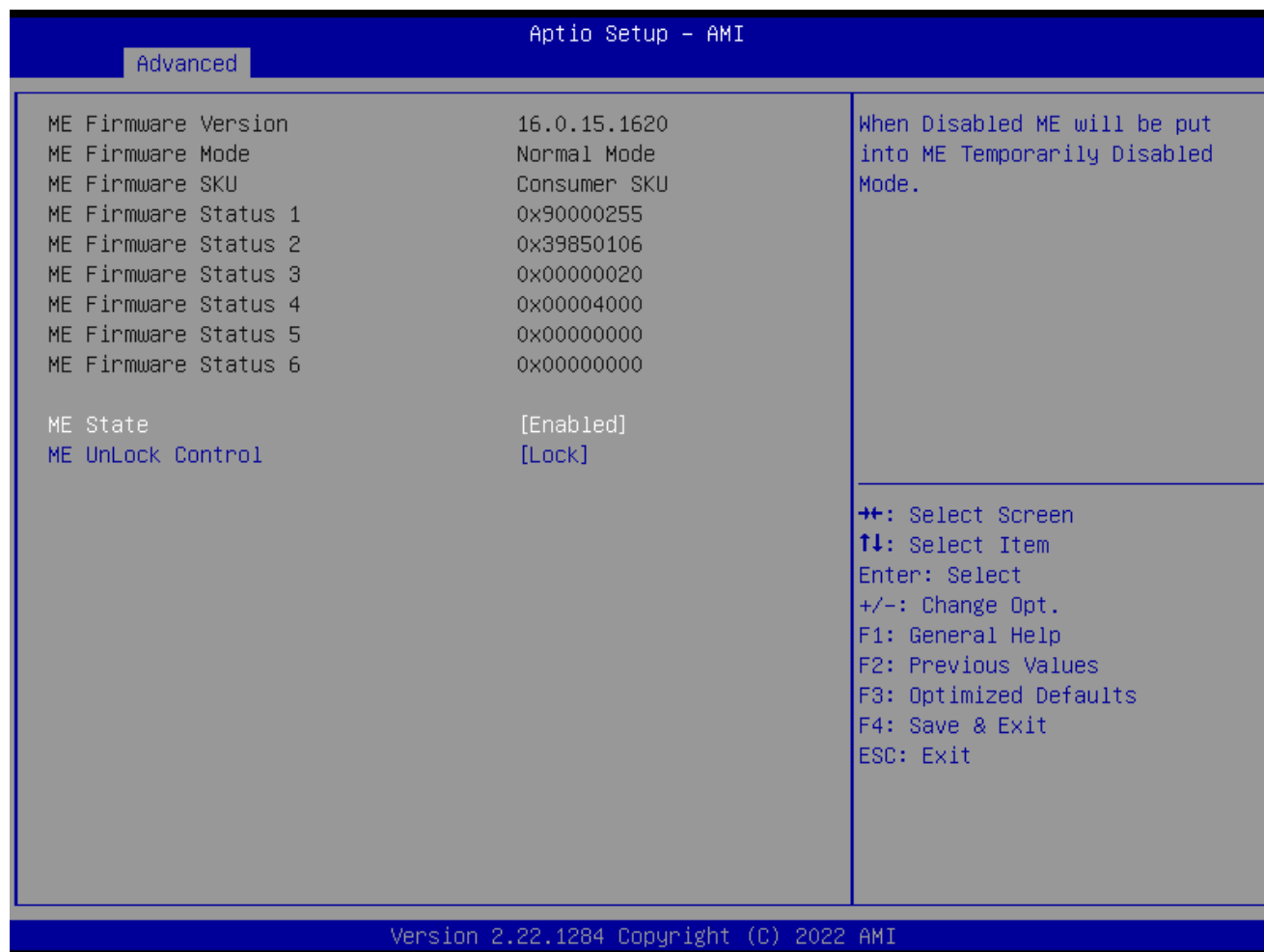

- **ME State [Enabled]**  
When disabled ME will be put into ME temporarily disabled mode  
Configuration options: [Enable] [Disable]
- **ME unlock control [Lock]**  
When Set unlock, system will shut down for active function  
Configuration options: [Lock] [Unlock]

2.4.4 Thunderbolt™ Configuration (optional feature)

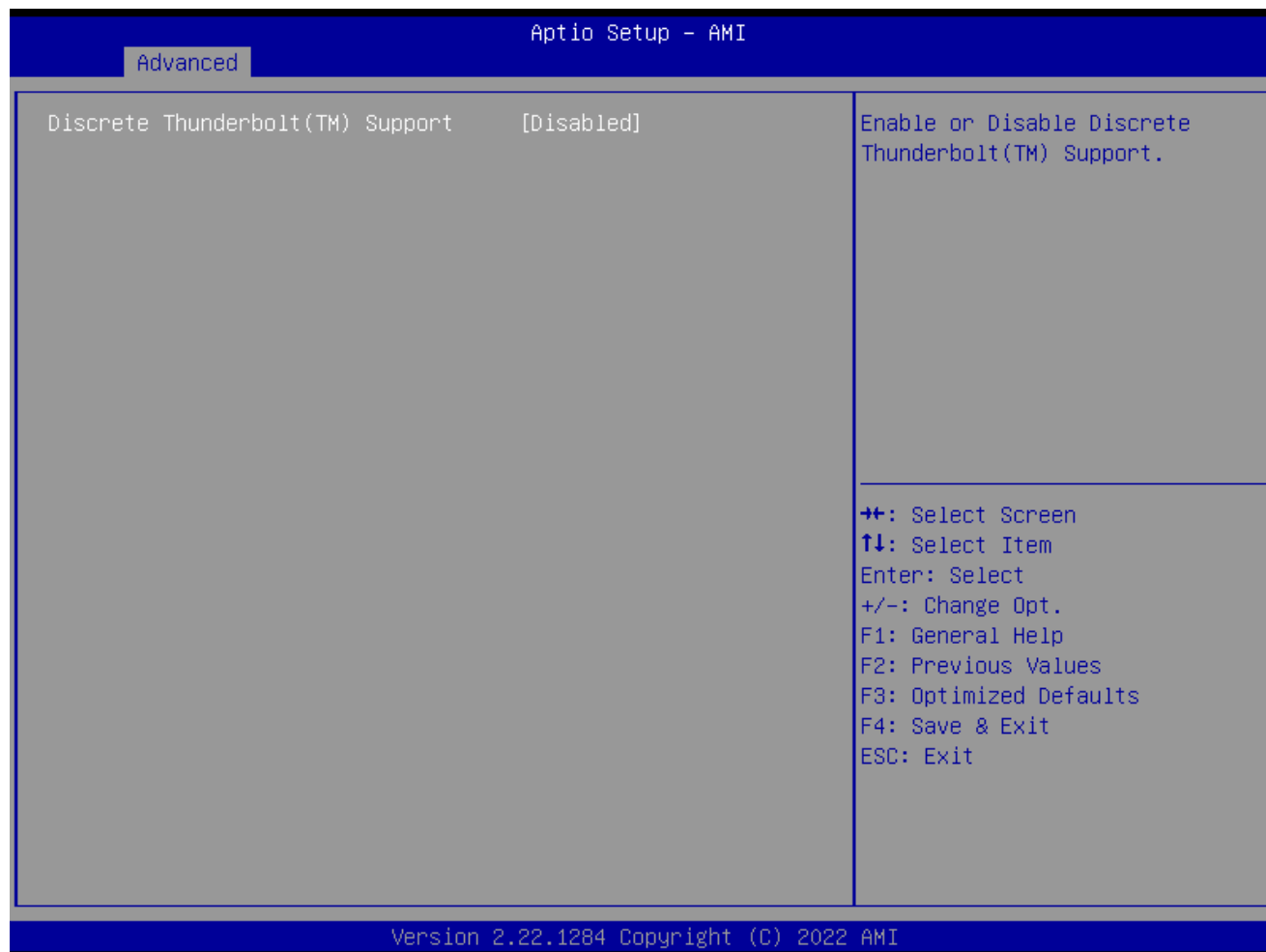

- **Discrete Thunderbolt™ support [Disabled]**  
Enabled or Disabled discrete thunderbolt support  
Configuration options: [Enable] [Disable]

## 2.4.5 Trusted Computing

### Security device settings

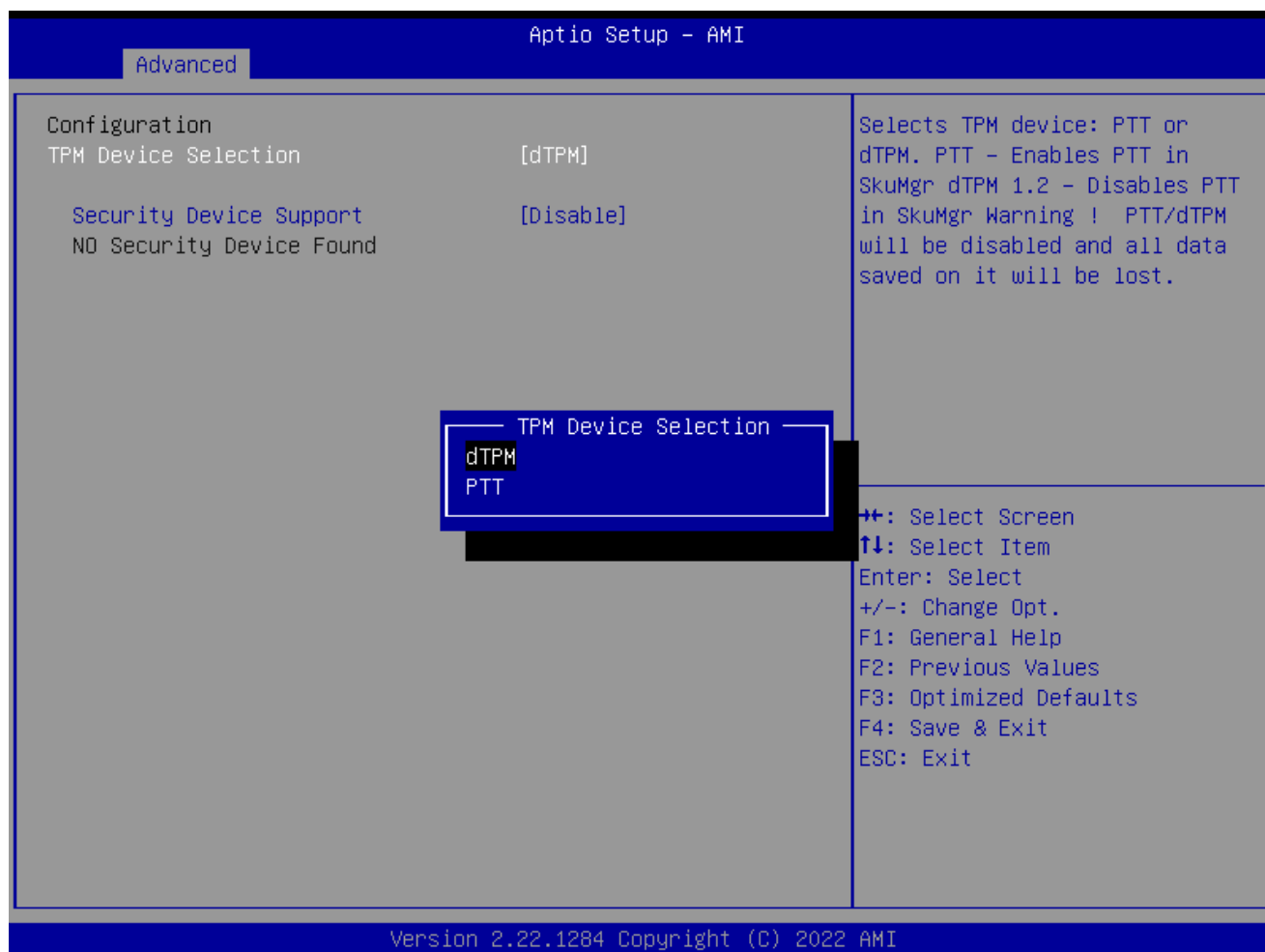

- **TPM Device Selection [dTPM]**  
Select TPM device  
Configuration options: [dTPM] [PTT]
- **Security Device support [Disabled]**  
Enable or Disable BIOS support security device  
Configuration options: [Enable] [Disable]

2.4.6 ACPI Settings

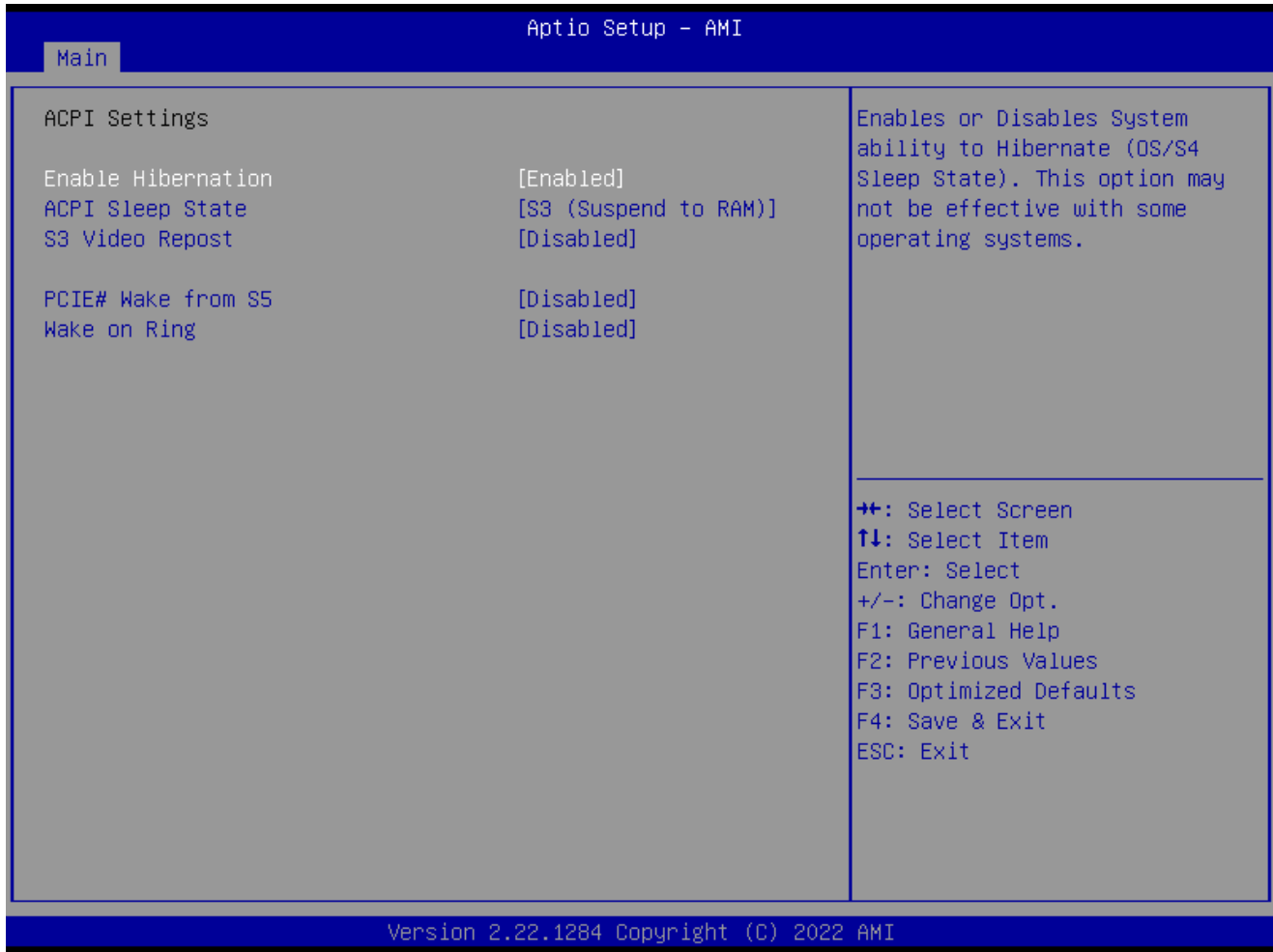

- **Enable Hibernation [Enable]**  
 Enable or Disable system ability to Hibernation.  
 Configuration options: [Enable] [Disable]
- **ACPI Sleep State [S3 (Suspend to RAM)]**  
 Select the highest ACPI sleep state the system will enter the SUSPEND button is press.  
 Configuration options: [Suspend Disable] [S3 (suspend to RAM )]
- **S3 Video Repost [Disabled]**  
 Enable or disable S3 video repost  
 Configuration options: [Disabled] [Enabled]
- **PCIE# wake from S5 [Disabled]**  
 Enable or disable PCIE wake the system from S5.  
 Configuration options: [Disabled] [Enabled]
- **Wake on Ring [Disabled]**  
 Enable or disable wake on ring function under ACPI S3/S4/S5.  
 Configuration options: [Disabled] [Enabled]

## 2.4.7 NCT6126D Super IO configuration

Provide NCT6126D super IO configuration settings

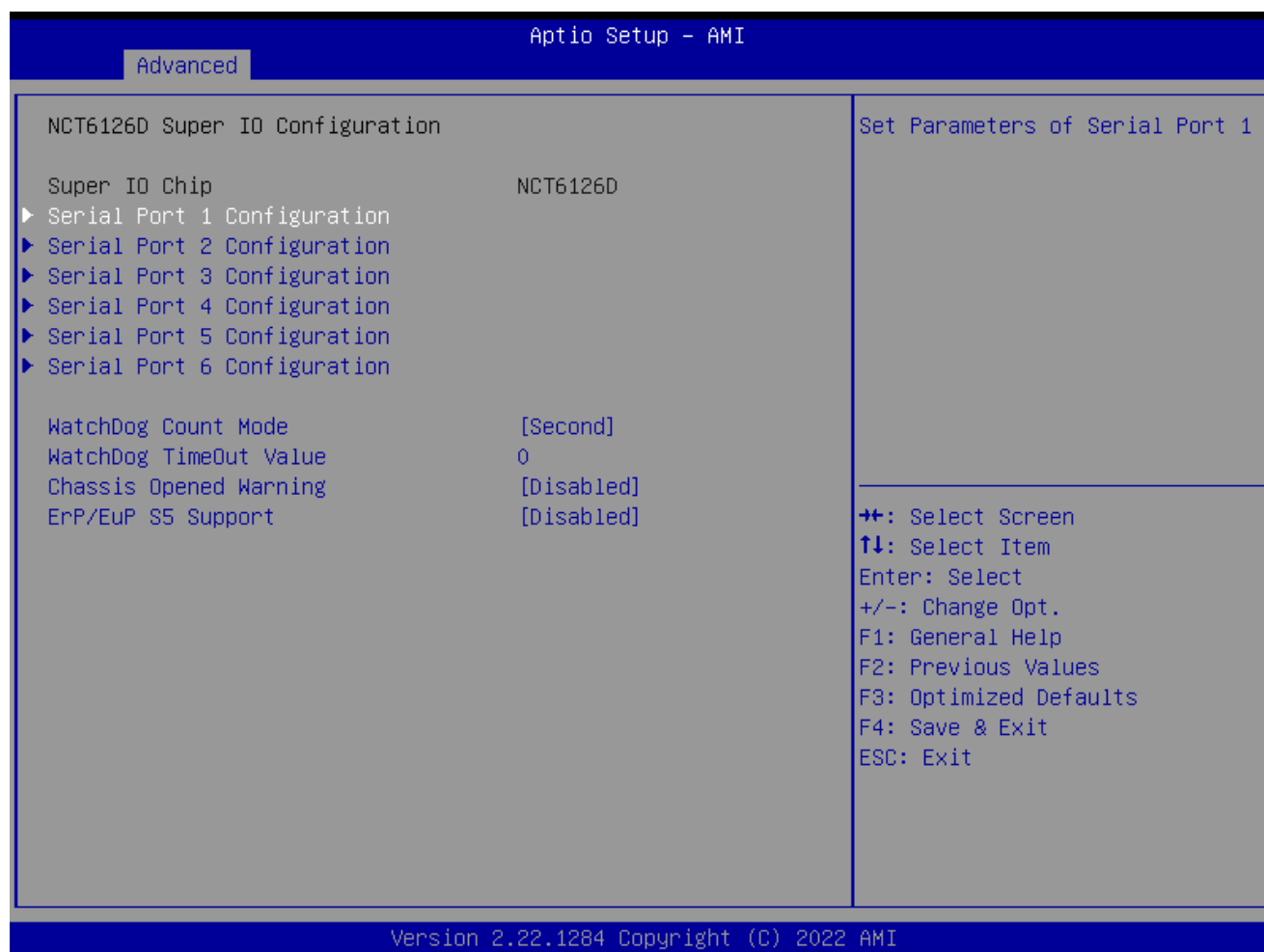

- **WatchDog count mode [Second]**  
WatchDog count mode Selection  
Configuration options: [Second] [Minute]
- **WatchDog Timeout value**  
Fill watchdog timeout value, 0 means disables
- **Chassis opened warning [Disabled]**  
Select chassis intrusion enabled to Disabled  
Configuration options: [Disabled] [Enabled]
- **ErP/EuP S5 Support [Disabled]**  
Configuration options: [Disabled] [Enabled]

# BC680R User's Manual

## 2.4.7.1 Serial Port 1 Configuration

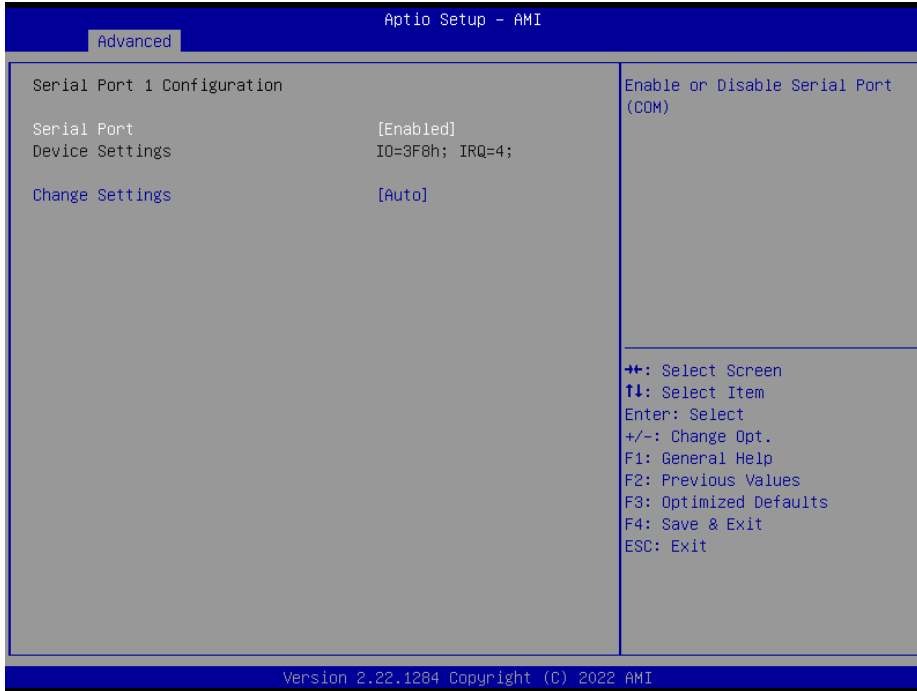

- **Serial Port [Enabled]**  
Enable or Disable serial Port (COM)  
Configuration options: [Disabled] [Enabled]
- **Change Setting [Auto]**  
Select an optimal settings for super IO device  
Configuration options: as below

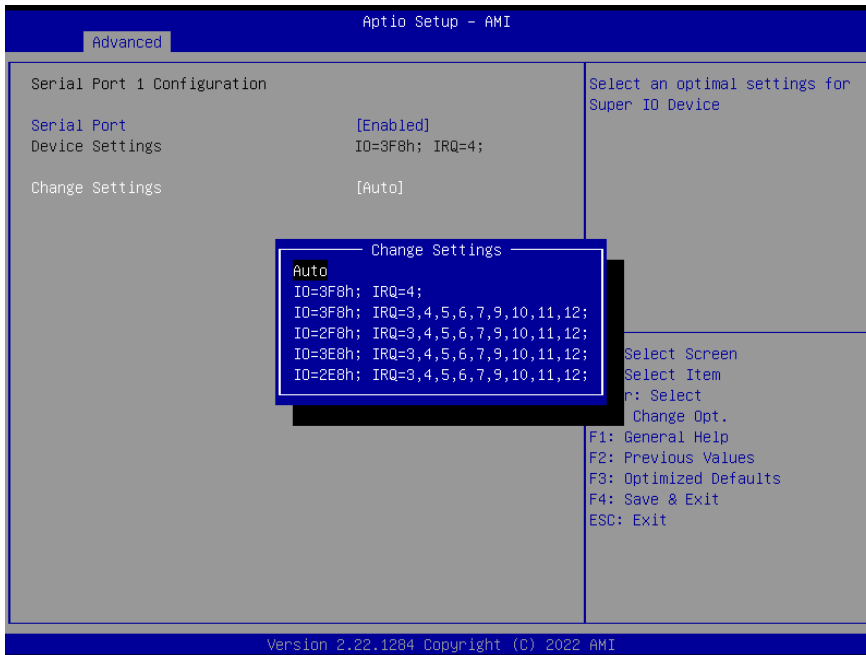

## 2.4.7.2 Serial Port 2 Configuration

- **Serial Port [Enabled]**  
Enable or Disable serial Port (COM)

Configuration options: [Disabled] [Enabled]

- **Change Settings [Auto]**

Select an optimal settings for super IO device

Configuration options: as below

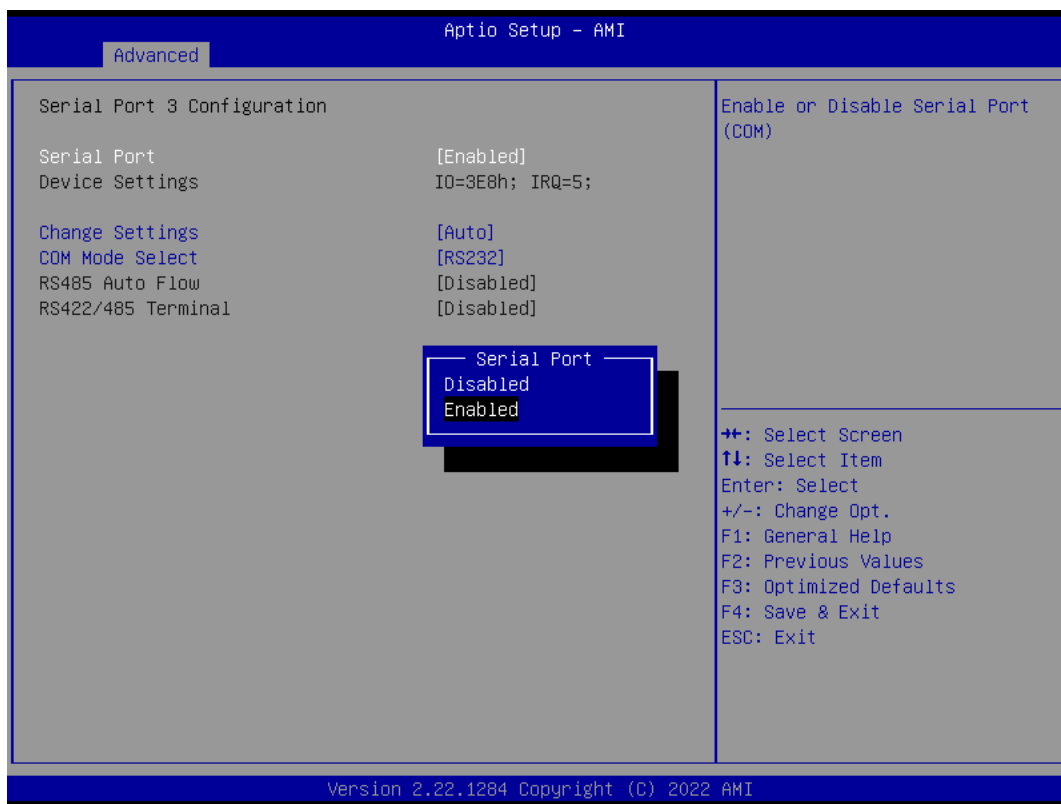

### 2.4.7.3 Serial Port 3 Configuration

- **Serial Port [Enabled]**

Enable or Disable serial Port (COM)

Configuration options: [Disabled] [Enabled]

- **Change Settings [Auto]**

Select an optimal settings for super IO device

Configuration options: as below

# BC680R User's Manual

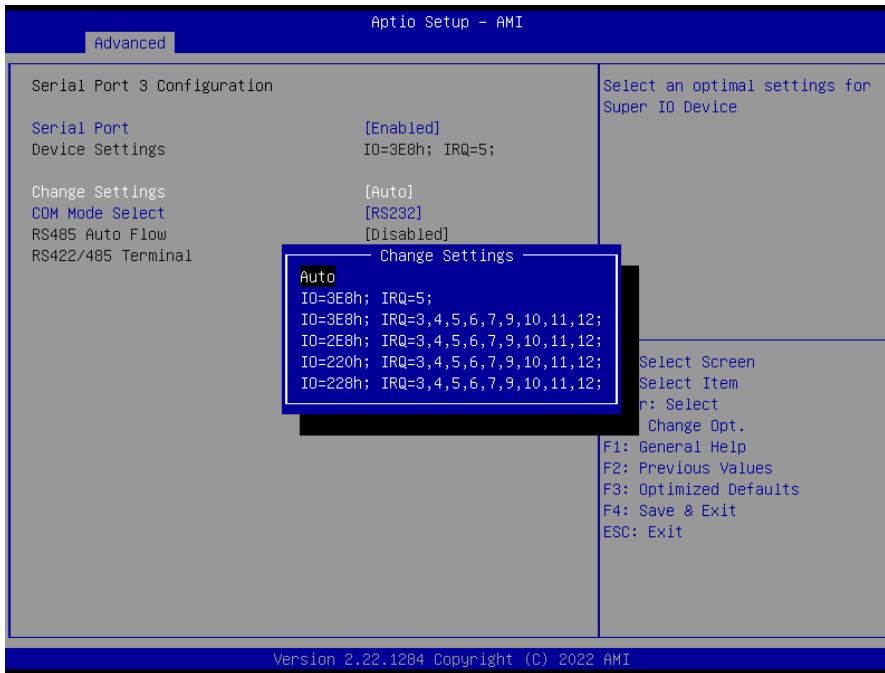

- **COM Mode Select [RS232]**  
Configure the COM port Mode  
Configuration options: [RS232][RS485 Half Duplex][RS422 Full Duplex]

## 2.4.7.4 Serial Port 4 Configuration

- **Serial Port [Enabled]**  
Enable or Disable serial Port (COM)  
Configuration options: [Disabled] [Enabled]
- **Change Settings [Auto]**  
Select an optimal settings for super IO device  
Configuration options: as below



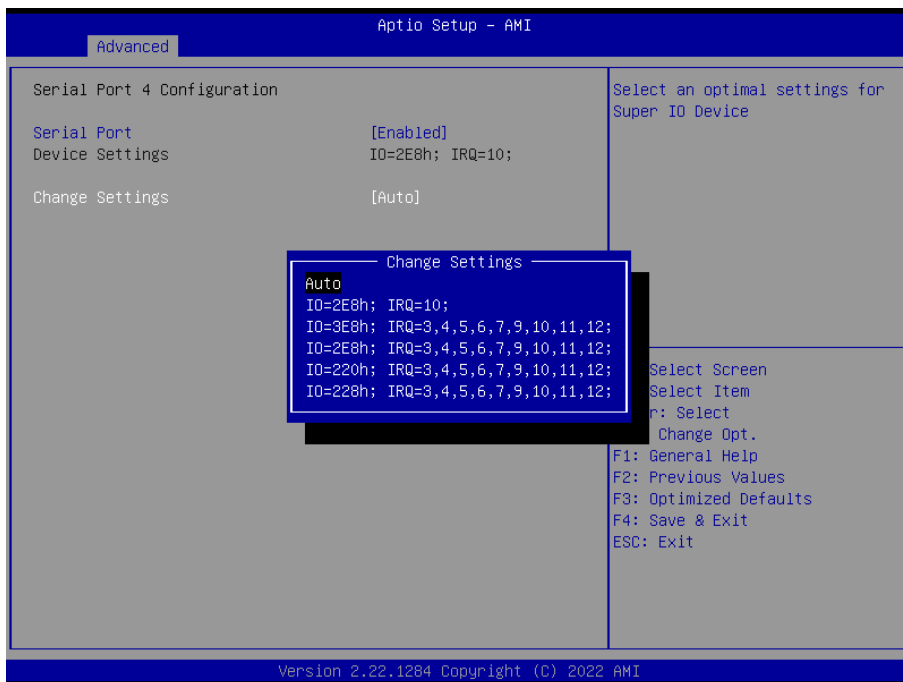

### 2.4.7.5 Serial Port 5 Configuration

- **Serial Port [Enabled]**  
Enable or Disable serial Port (COM)  
Configuration options: [Disabled] [Enabled]
- **Change Settings [Auto]**  
Select an optimal settings for super IO device  
Configuration options: as below

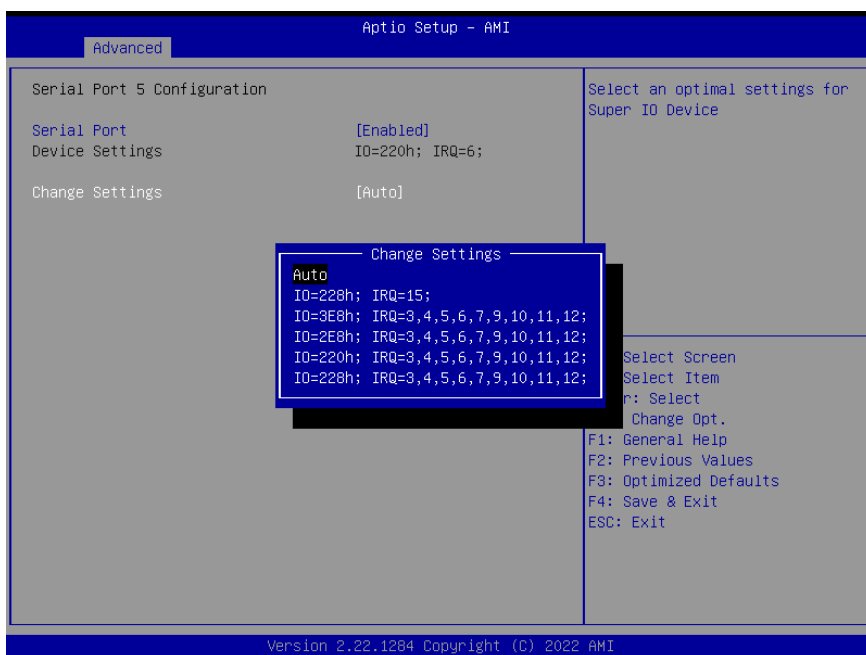

# BC680R User's Manual

## 2.4.7.6 Serial Port 6 Configuration

- **Serial Port [Enabled]**  
Enable or Disable serial Port (COM)  
Configuration options: [Disabled] [Enabled]
- **Change Settings [Auto]**  
Select an optimal settings for super IO device  
Configuration options: as below

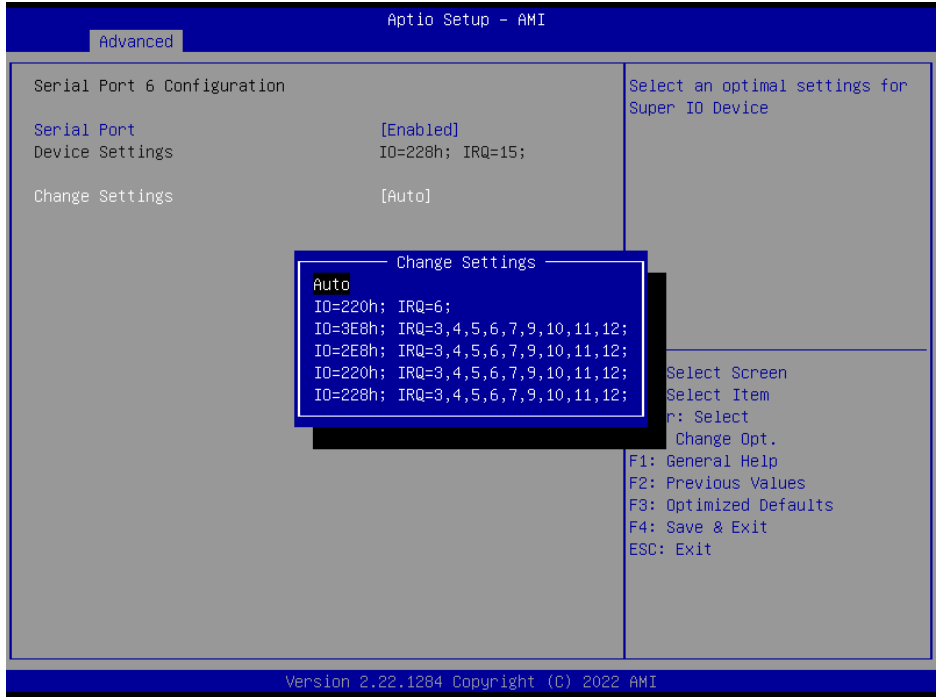

## 2.4.8 Hardware monitor

Display Hardware monitor information

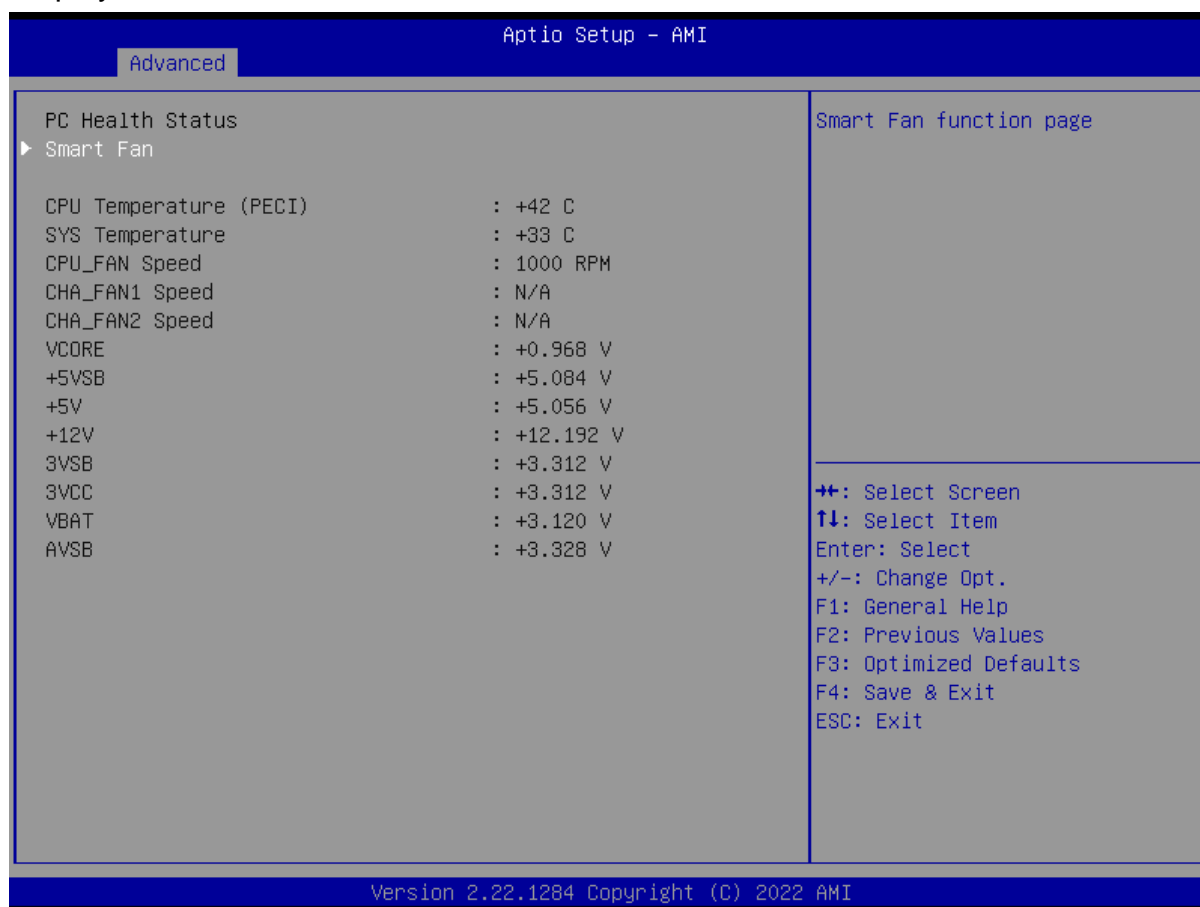

### 2.4.8.1 Smart FAN



- **Smart FAN Function [Enabled]**

# BC680R User's Manual

Smart fan function Enable/Disabled

Configuration options: [Enabled] [Disabled][Manual]

## - 2.4.8.1.1 Smart FAN mode Configuration

Setting different FAN on this motherboard



- **SYS\_FAN1/CPU\_FAN1/CHA\_FAN1 FAN Target**

Smart FAN target temperature

Configuration options: Please see below picture

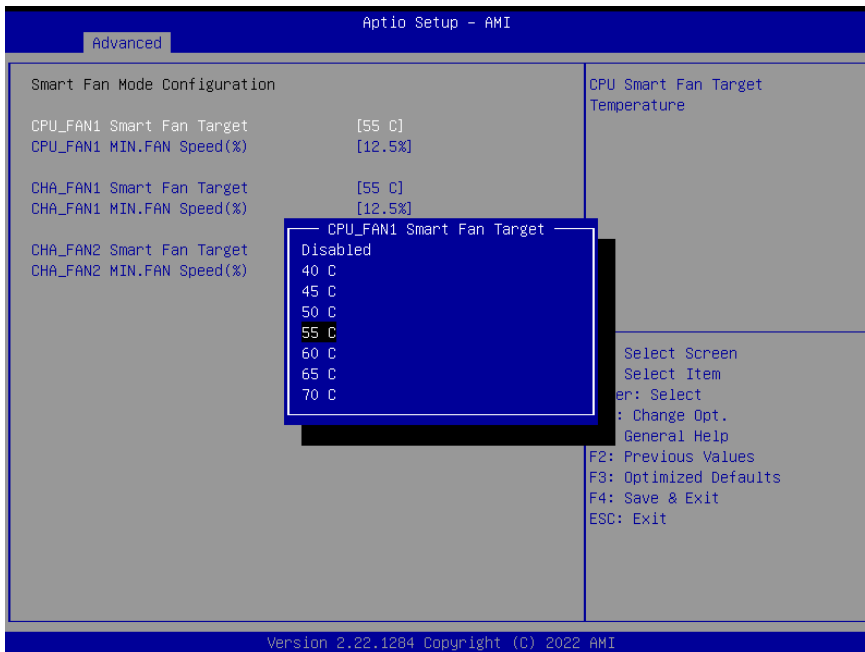

- **CPU\_FAN1/CHA\_FAN1/CHA\_FAN2 MIN.FAN Speed (%)**

CPU or Chassis Smart FAN minimum settings

Configuration options: Please see below picture

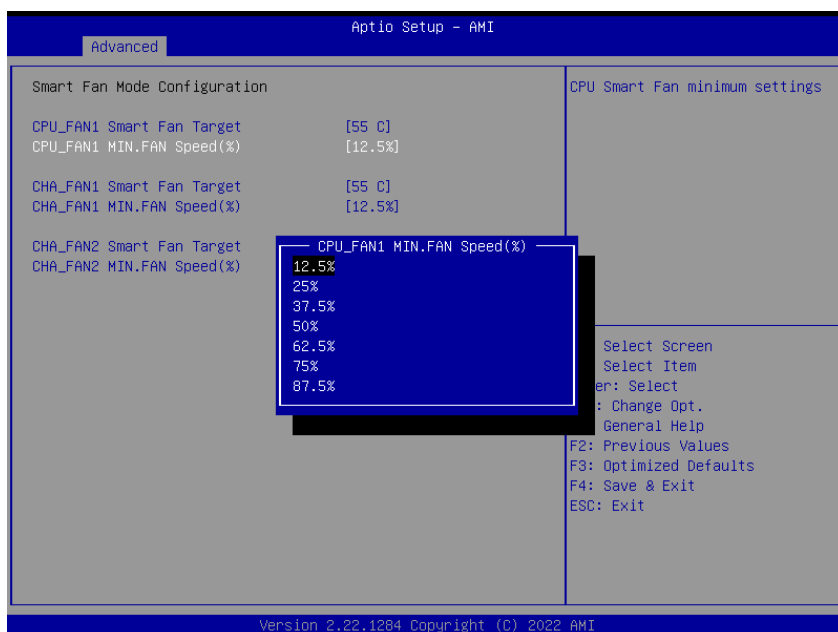

### 2.4.9 S5 RTC wake settings

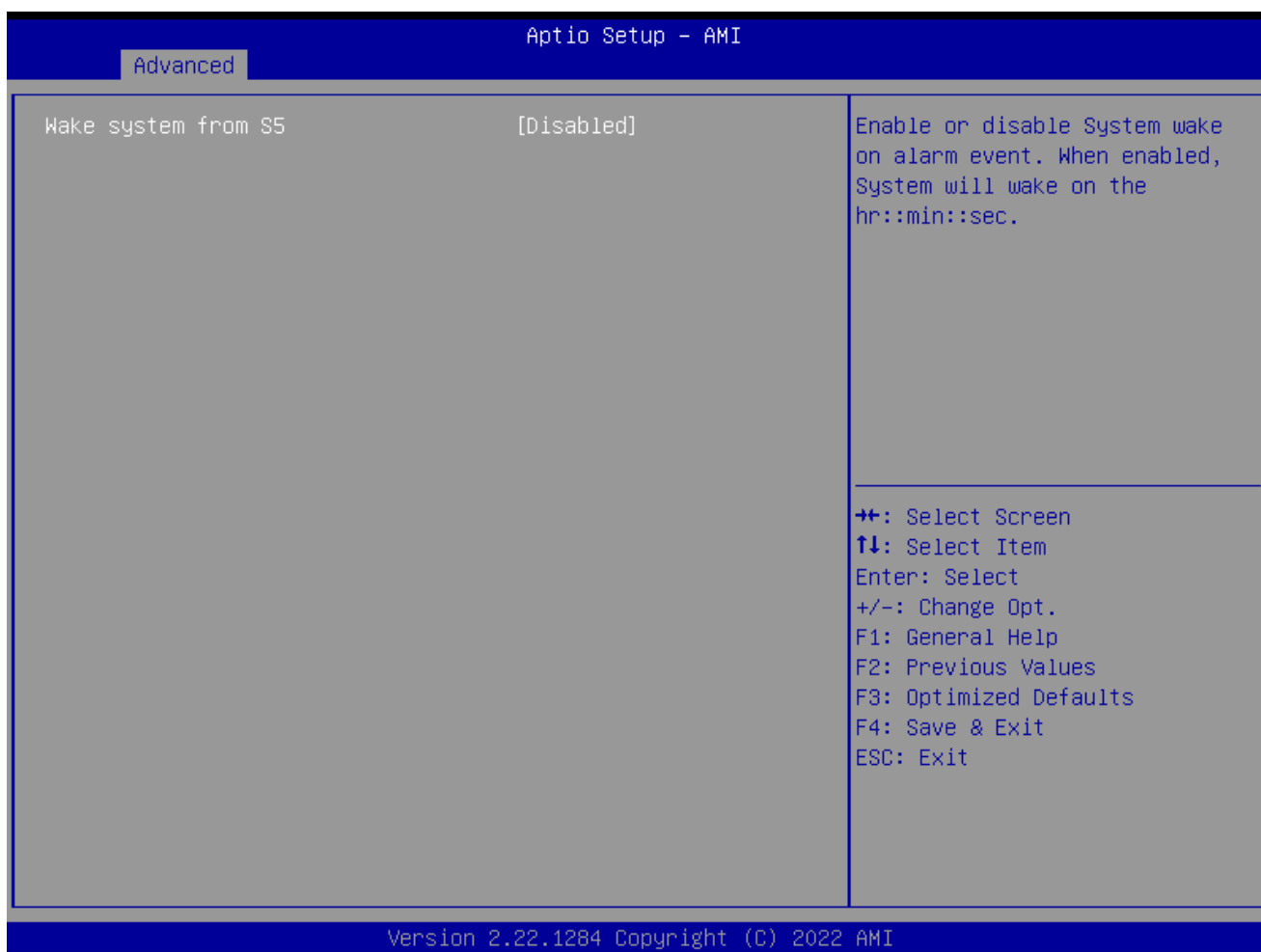

- **Wake system from S5 [Disabled]**  
 Enabled or Disabled system wake on alarm event  
 Configuration options: [Enabled] [Disabled]

## BC680R User's Manual

### 2.4.10 Serial Port Console Redirection

Display CPU configuration



- **Console Redirection [Disabled]**

Enabled or Disabled COM1 Console redirection

Configuration options: [Disabled][Enabled]

#### **2.4.10.1 Console Redirection settings**

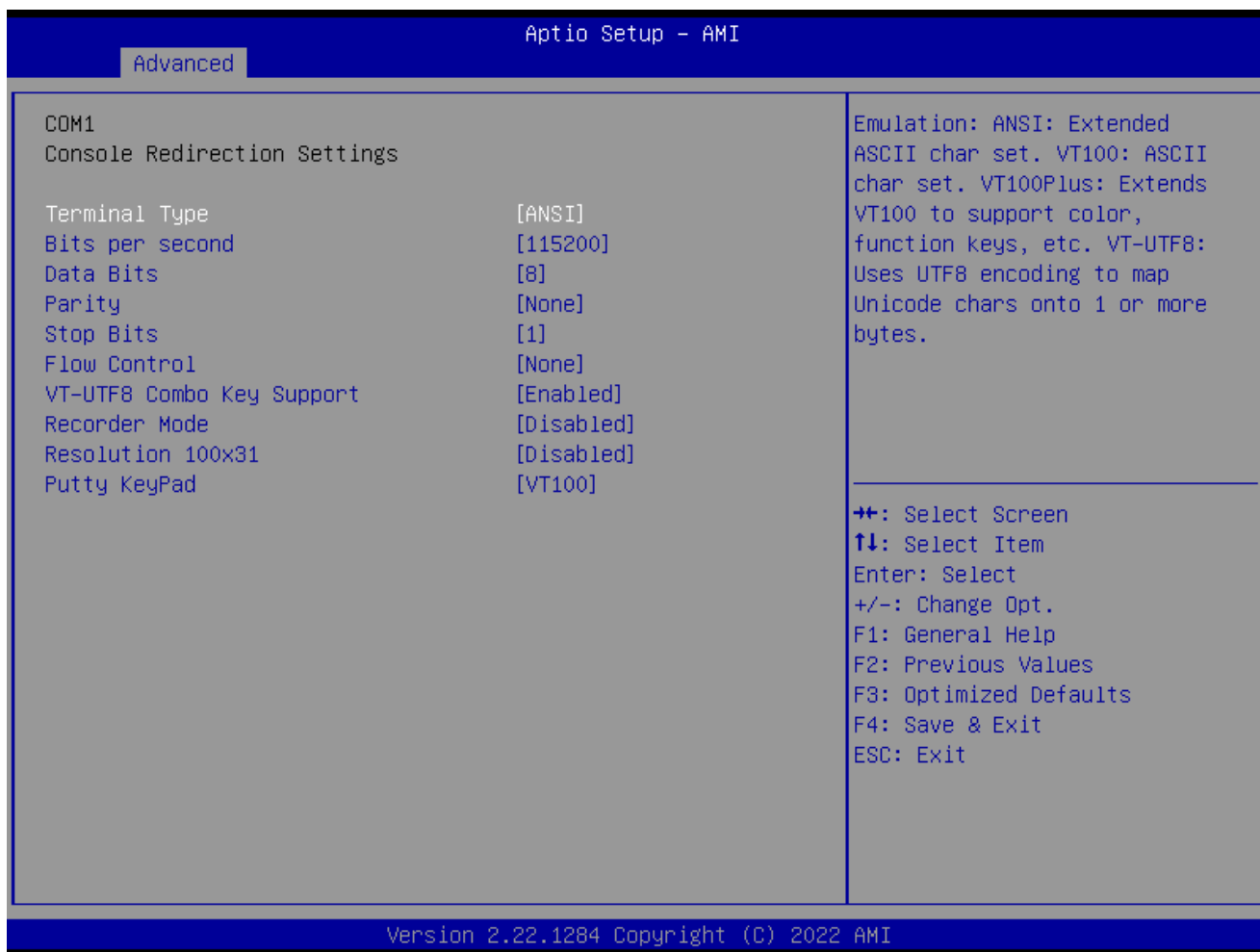

- **Terminal Type[ANSI]**  
Select terminal type  
Configuration options: [VT100][VT100Plus][VT-UTF8][ANSI]
- **Bits per second[115200]**  
Select serial port transmission speed  
Configuration options: [9600][19200][38400][57600][115200]
- **Bits per second[115200]**  
Select data bits  
Configuration options: [7][8]
- **Parity[None]**  
A parity bit can be sent with the data bits to detect some transmission errors  
Configuration options: [None][Even][Odd][Mark][Space]
- **Stop Bits[1]**  
Stop bits indicate the end of a serial data package  
Configuration options: [1][2]
- **Flow Control[None]**  
Flow control can prevent data loss from buffer overflow.  
Configuration options: [None][Hardware RTS/CTS]
- **VT-UTF8 Combo key Support [Enabled]**

## BC680R User's Manual

Enable VT-UTF8 combination key support for ANSI/VT100 terminals

Configuration options: [Enabled] [Disabled]

- **Recorder Mode [Disabled]**

With this mode enabled only text will be sent.

Configuration options: [Enabled] [Disabled]

- **Resolution 100x31 [Disabled]**

Enables or disables extended terminal resolution

Configuration options: [Enabled] [Disabled]

- **Putty Keypad [VT100]**

Selects function key and keypad on putty

Configuration options: [VT1000] [LINUX][XTERMR6][SCO][ESCN][VT400]

### 2.4.11 Intel TXT information

Display Intel TXT information. This depends on CPU sku.

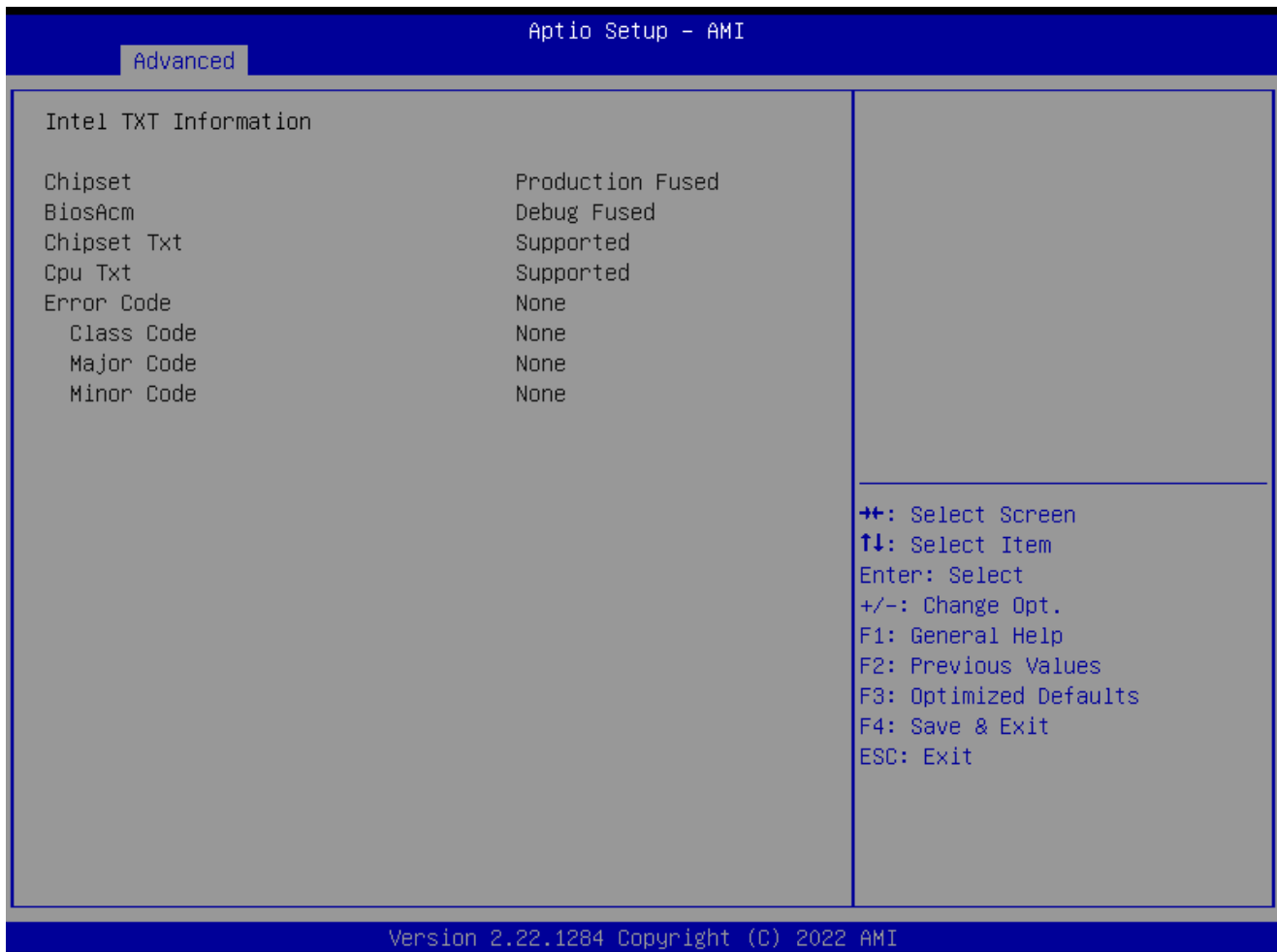



2.4.12 USB configuration

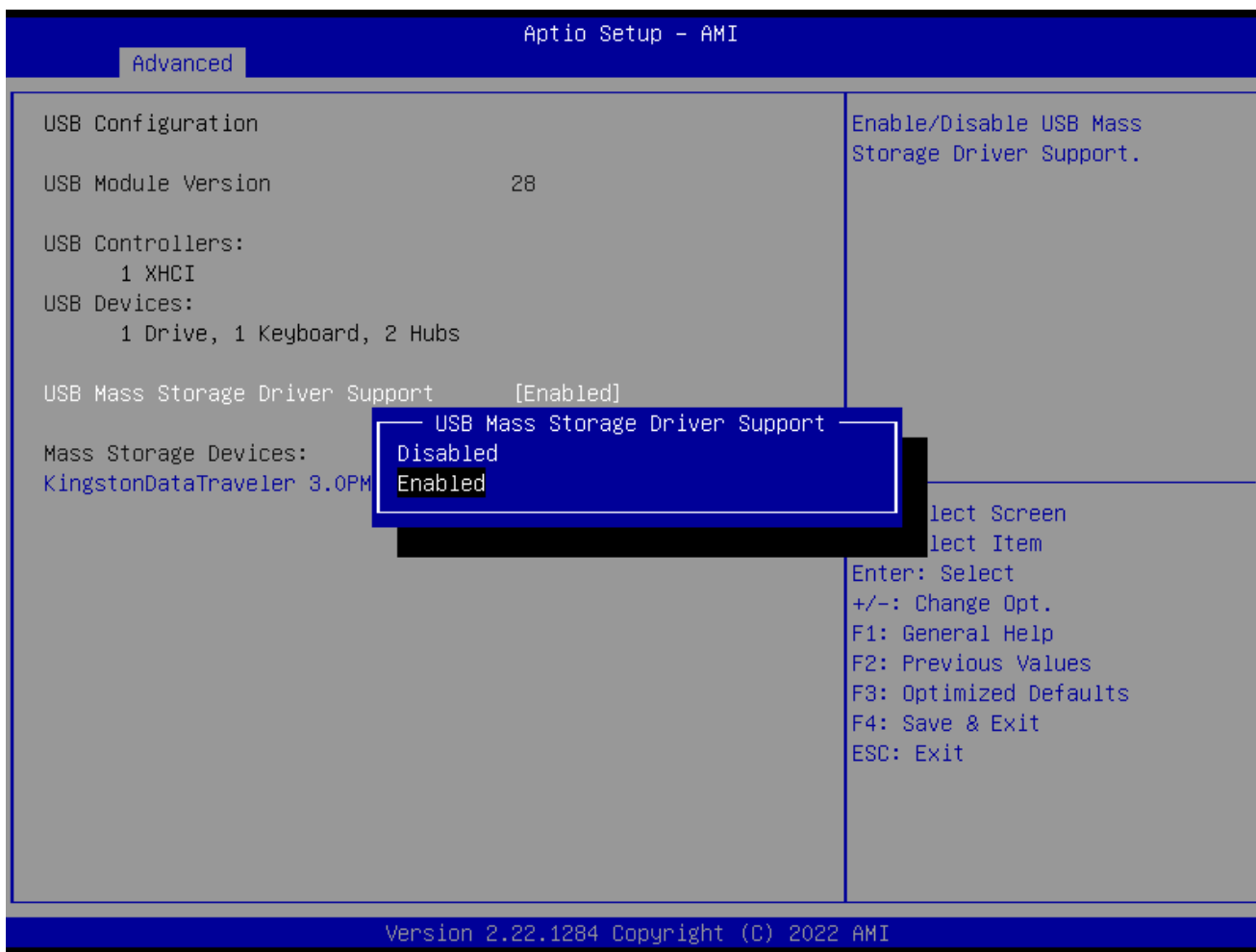

- **USB Mass Storage Driver Support [Enabled]**  
 Enable or Disable USB Mass Storage Driver Support  
 Configuration options: [Enabled][Disabled]
- **Mass Storage Devices [Auto]**  
 Mass Storage device emulation Type. "Auto" enumerates device according to its media format.

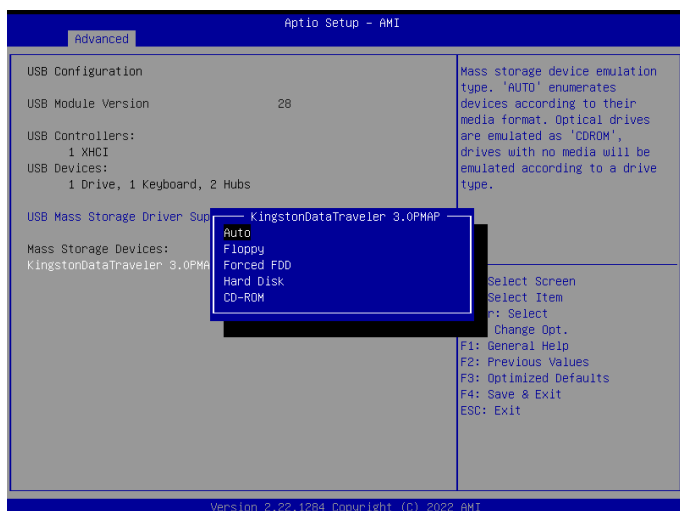

## BC680R User's Manual

### 2.4.13 Network Stack Configuration

#### Network Stack setting

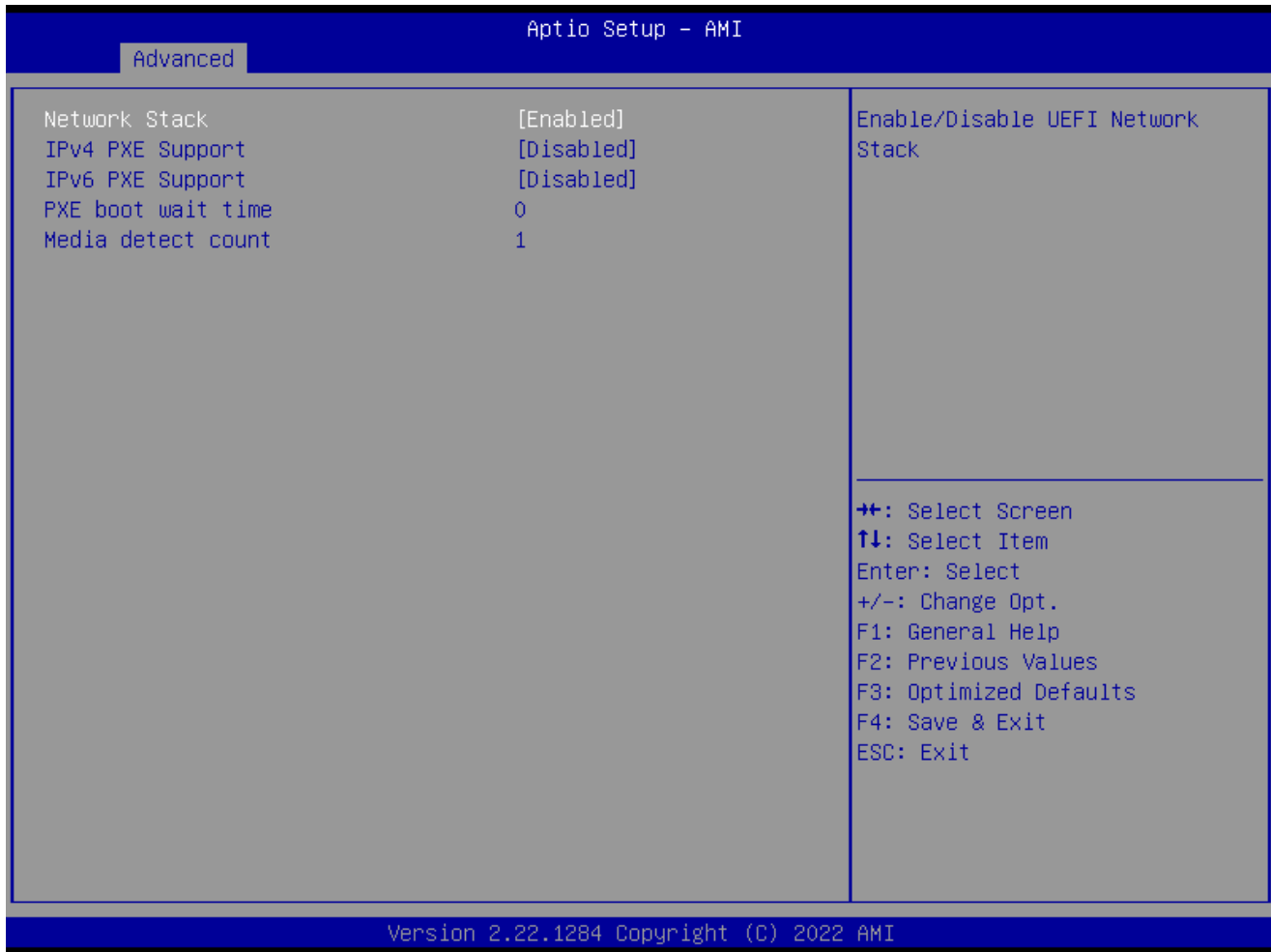

- **Network Stack [Disabled]**  
Enabled/Disabled UEFI Network Stack  
Configuration options: [Enabled][Disabled]
- **IPv4 PXE Support [Disabled]**  
Enabled or disabled IPv4 PXE boot Support  
Configuration options: [Enabled][Disabled]
- **IPv6 PXE Support [Disabled]**  
Enabled or disabled IPv6 PXE boot Support  
Configuration options: [Enabled][Disabled]
- **PXE boot wait time**  
Wait time in seconds to press ESC key to abort the PXE boot.
- **Media detect count**  
Number of time the presence of media will be checked

## 2.4.14 IP configuration

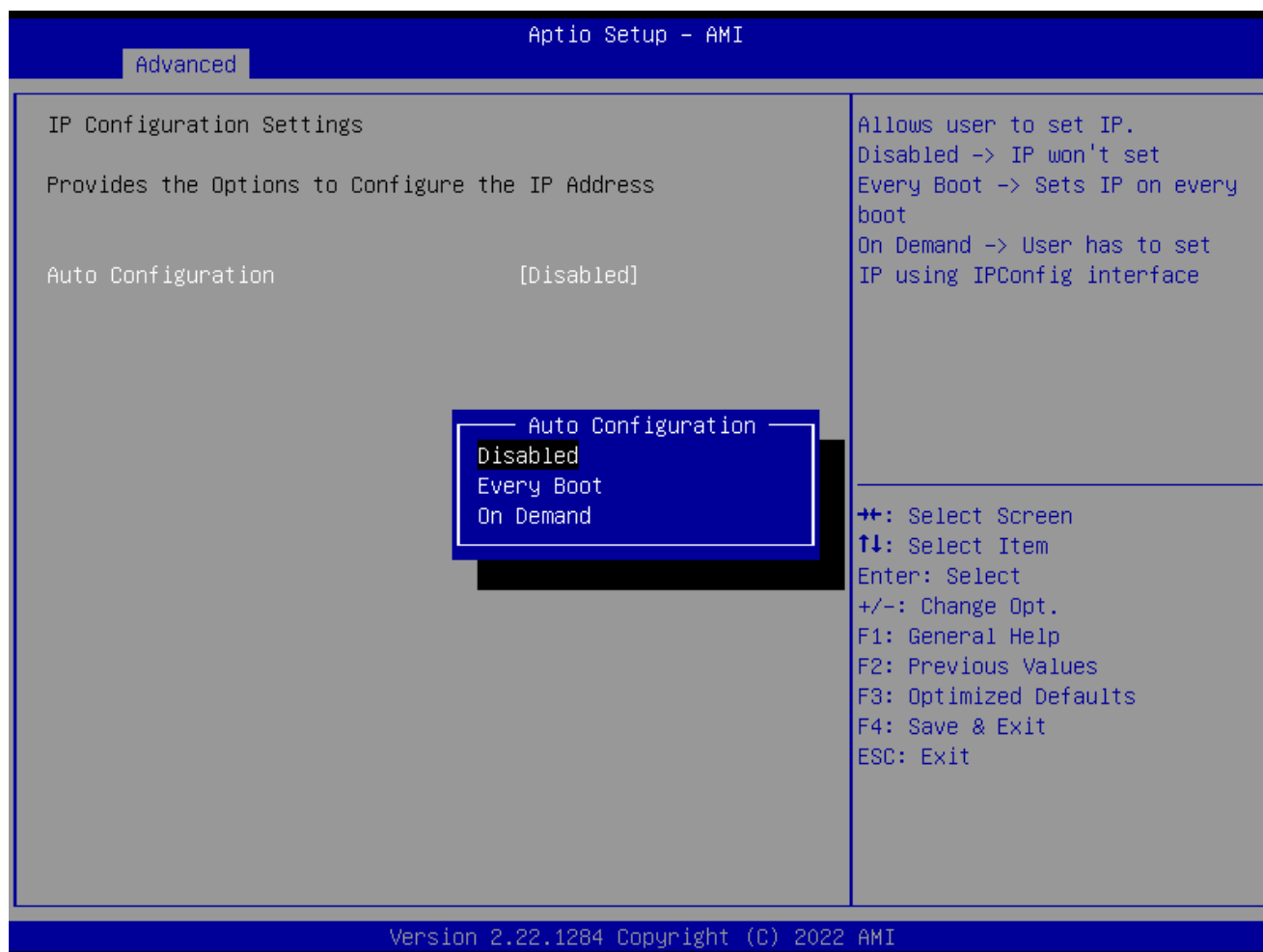

- **Auto Configuration[Disabled]**

Allow user to set IP.

Disabled→IP won't set

Every Boot→Sets IP on every boot

On demand→User has to set IP using IPConfig interface.

## 2.4.15 NVMe Configuration

Display NVMe controller or Drive information

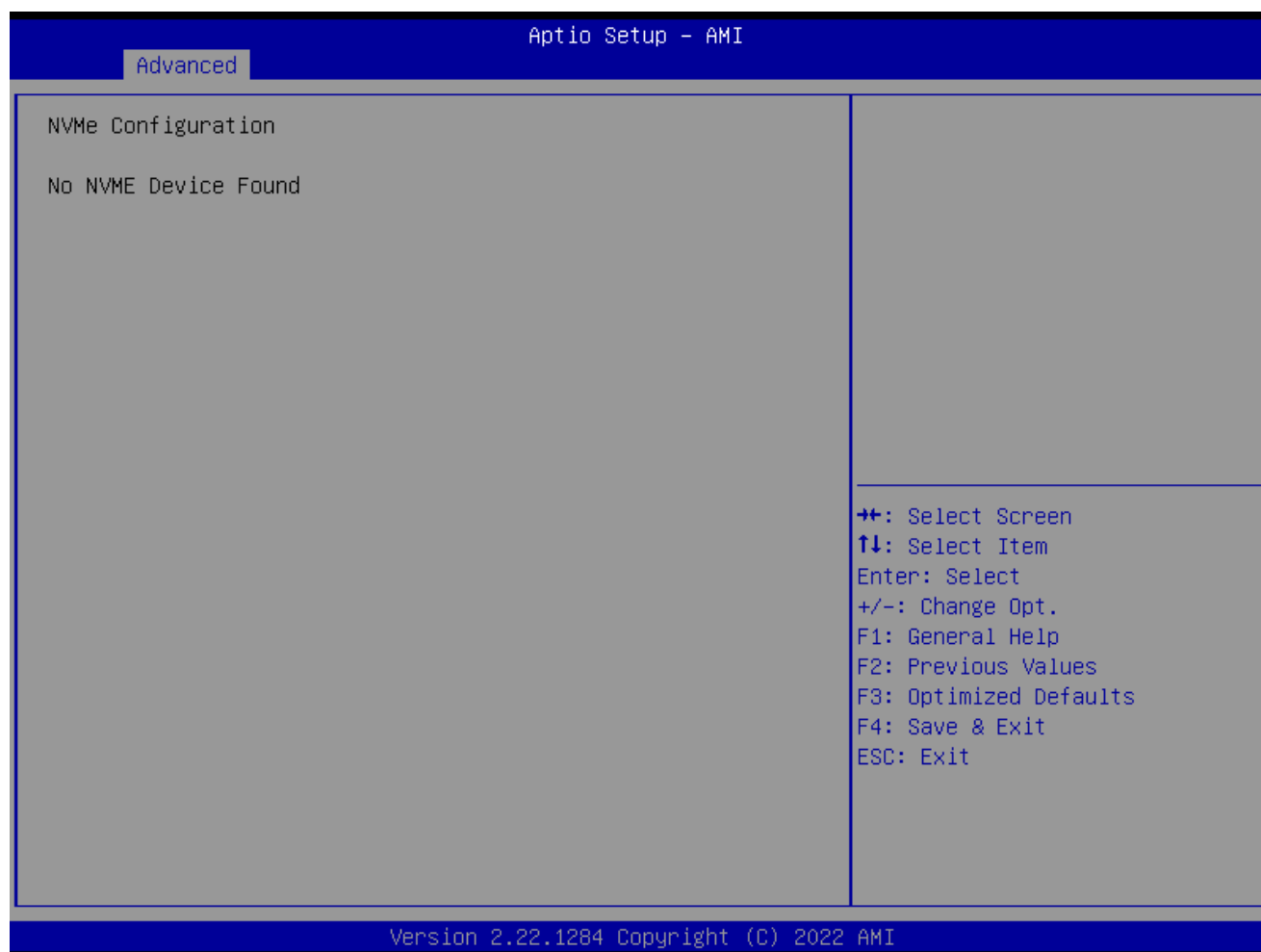

## 2.4.16 Remote Server Configuration

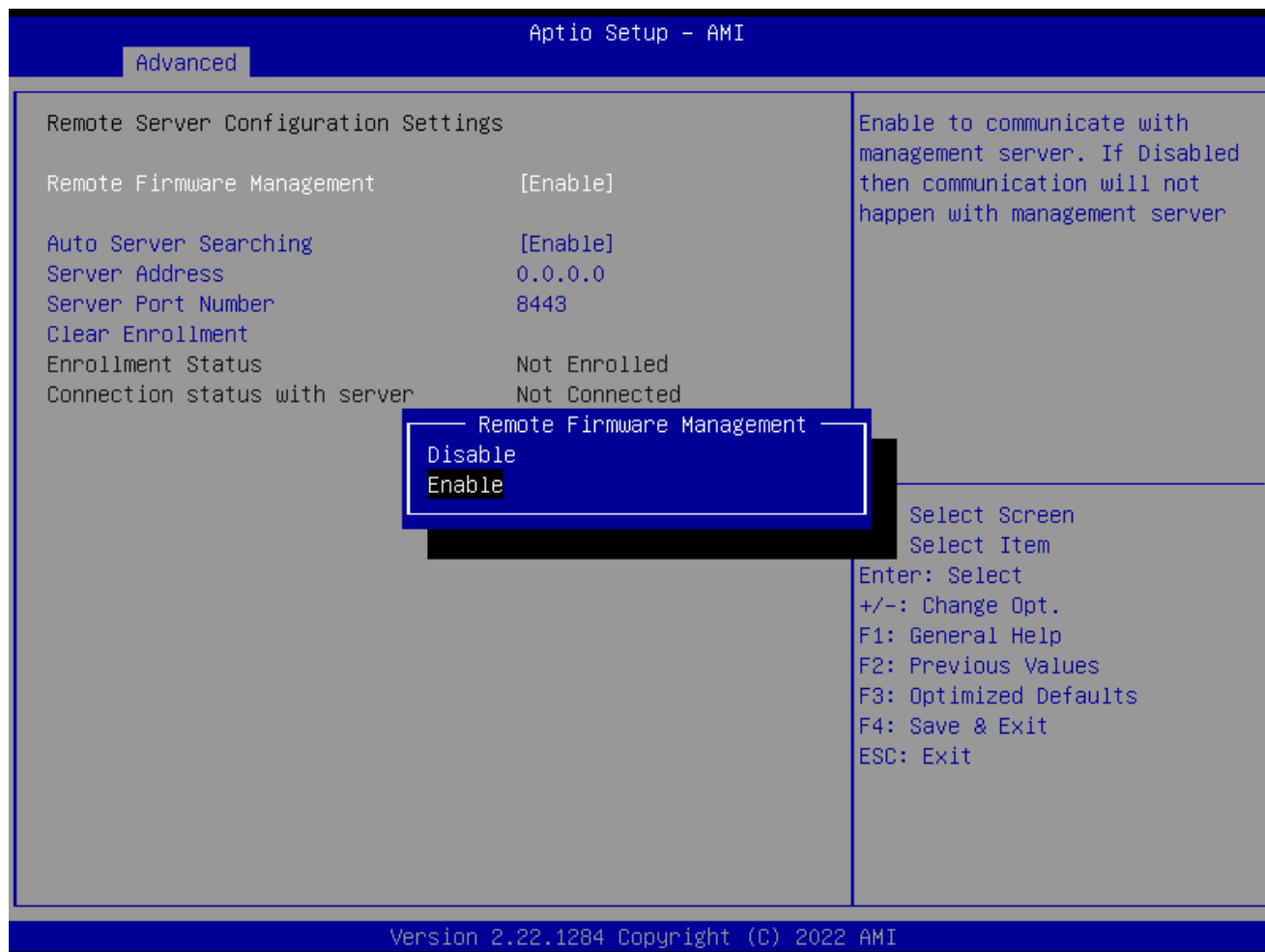

- **Remote Firmware Management [Enabled]**  
Enable to communicate with management server.  
Configuration options: [Disabled][Enabled]
- **Auto Server searching [Enabled]**  
Enabled to obtain DHCP server IP automatically. Disabled to provide Server IP manually.  
Need to do clear Enrollment, if server is changed to DHCP.  
Configuration options: [Enabled][Disabled]
- **Server Address [Enabled]**  
Management server address to be used if Auto server searching is either disabled or failed. If changed, need to do clear Enrollment if already enrolled with previous IP.

## BC680R User's Manual

### 2.5 Chipset

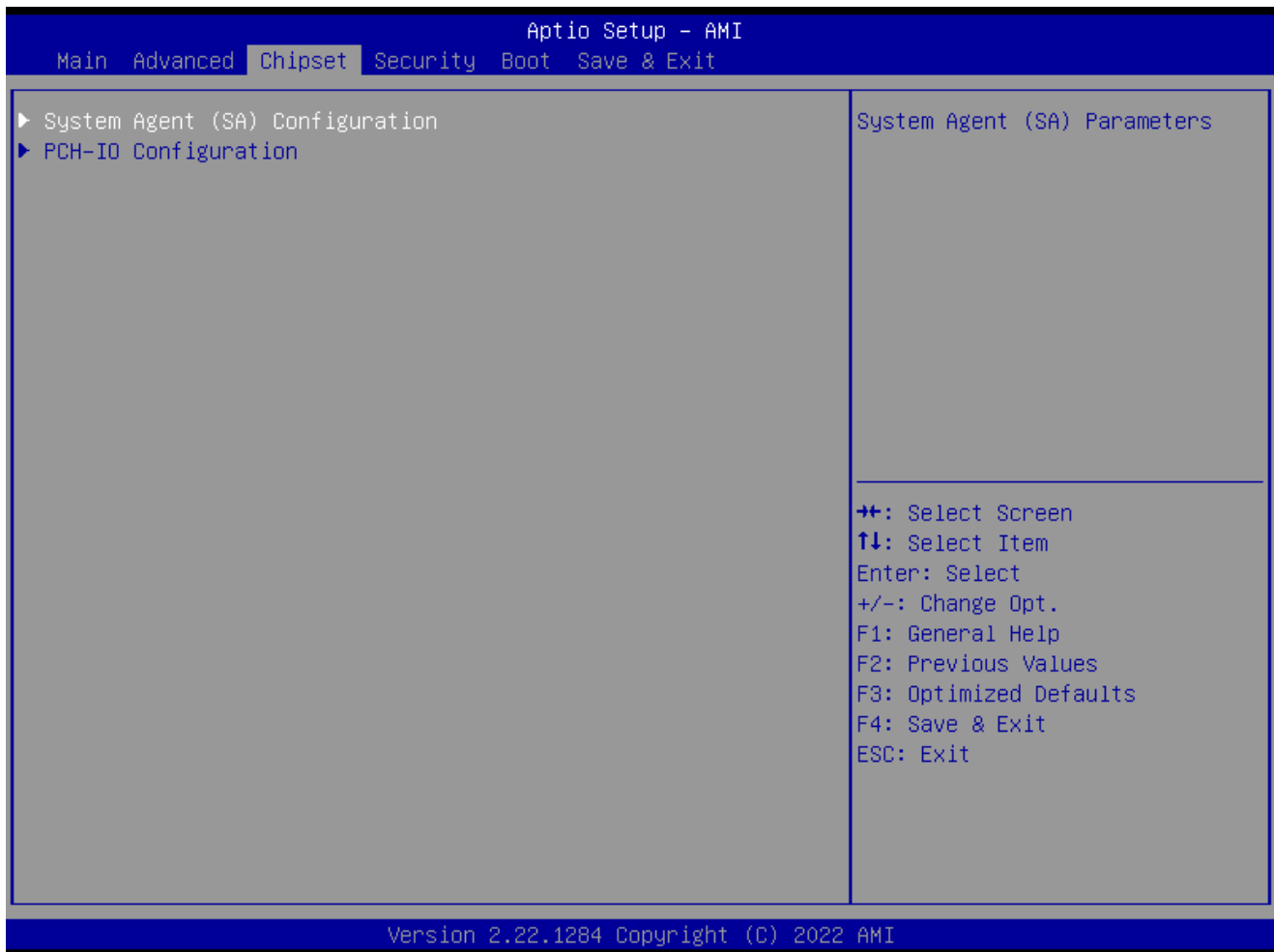

## 2.5.1 System Agent (SA) Configuration

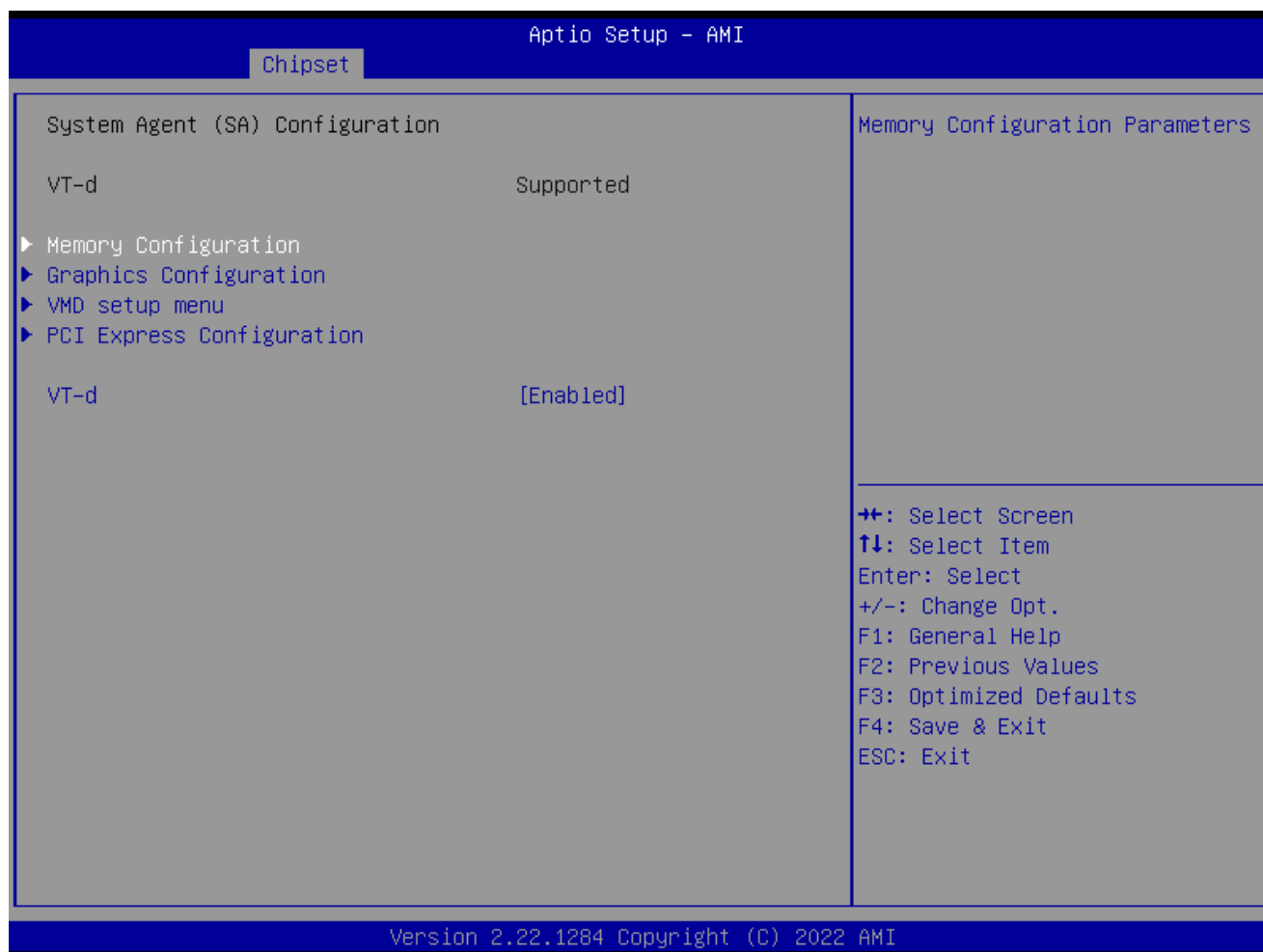

- **VT-d [Enabled]**

VT-d capability

Configuration options: [Disabled] [Enabled]

### 2.5.1.1 Memory Configuration

Maximum Value of TOLUD. Dynamic assignment would adjust TOLUD automatically based on largest MMIO length of installed graphic controller.



# BC680R User's Manual

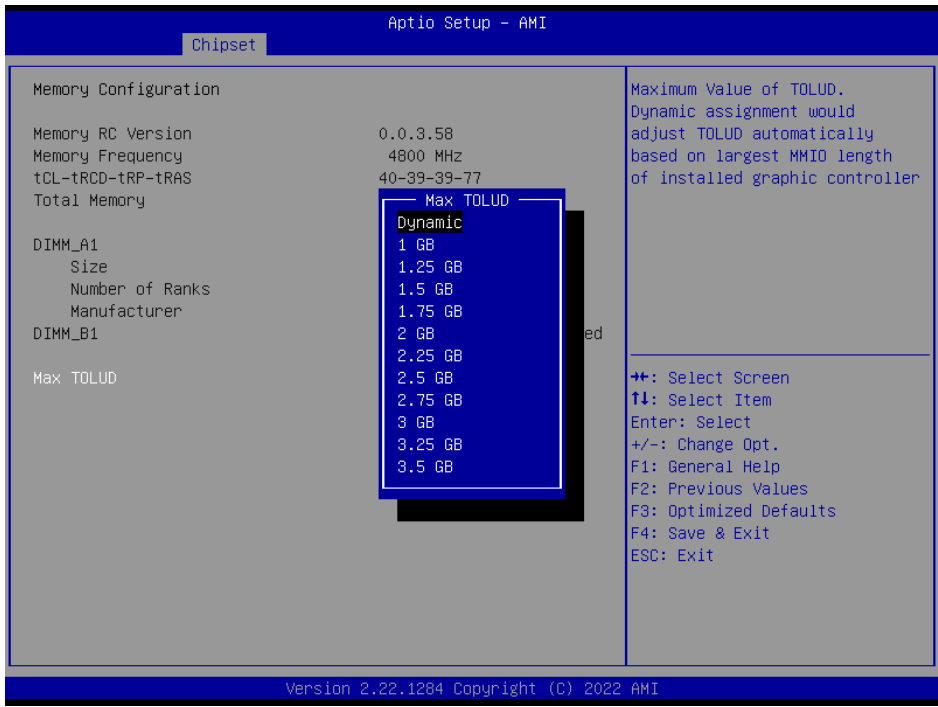

## 2.5.1.2 Graphic Configuration

### Graphic configuration settings

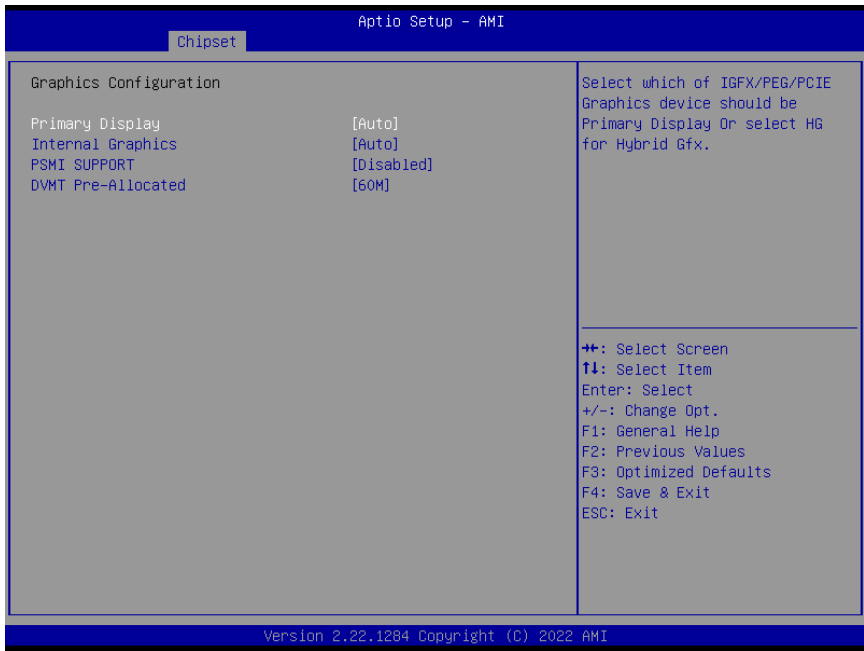

- **Primary Display[Auto]**

Select which of IGFX/PEG/PCIE graphic device should be primary display or select HG for Hybrid Gfx.

Configuration options: [Auto] [IGFX][PEG slot][PCIE]

- **Internal Graphics [Auto]**

Keep IGFX enabled based on the setup options

Configuration options: [Auto] [disabled][enabled]

- **PSMI Support [Disabled]**

PSMI enabled/Disabled

Configuration options: [Disabled][Enabled]

- **DVMT Pre-allocated [60M]**

Select DVMT 5.0 Pre-allocated (Fixed) Graphics memory size used by the internal graphics device.

Configuration options: As below picture

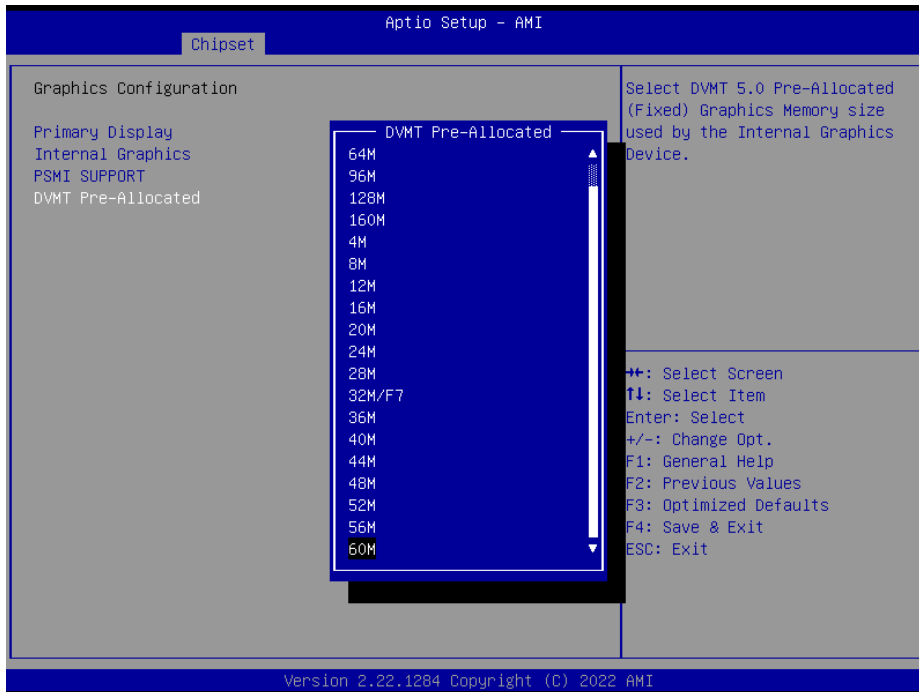

### 2.5.1.3 VMD setup menu

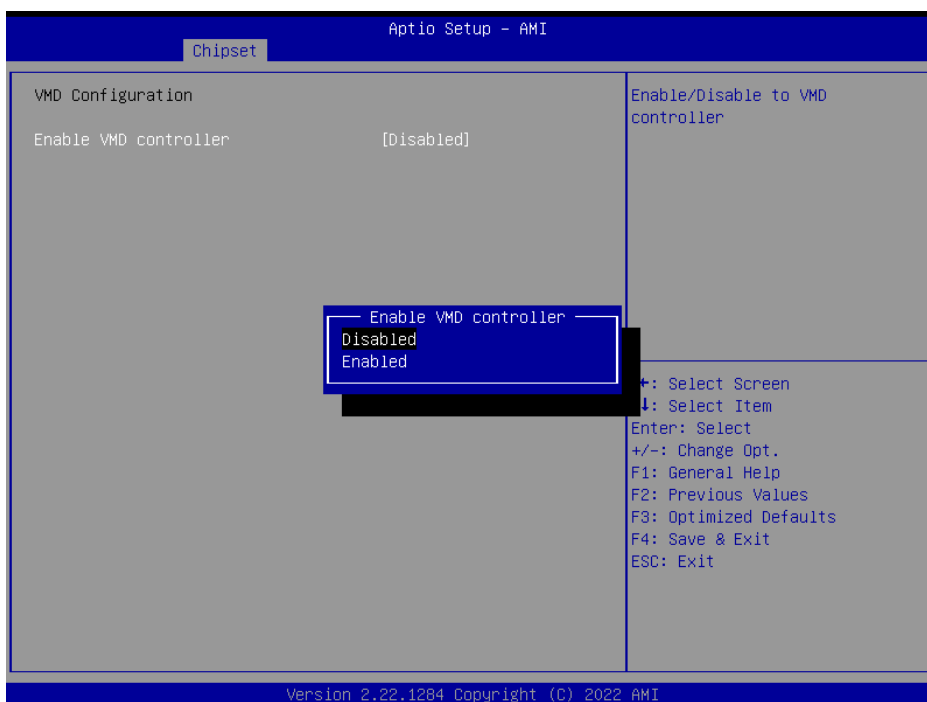

## BC680R User's Manual

- **Enable VMD controller [Disabled]**

Enable/Disable to VMD controller

Configuration options: [Disabled][Enabled]

### 2.5.1.4 PCI Express Configuration



- **Detect Non-compliance Device [Disabled]**

Detect Non-compliance Device in PEG

Configuration options: [Disabled][Enabled]

- **2.5.1.4.1 PCI Express Root Port 1 (x4 Key M)**

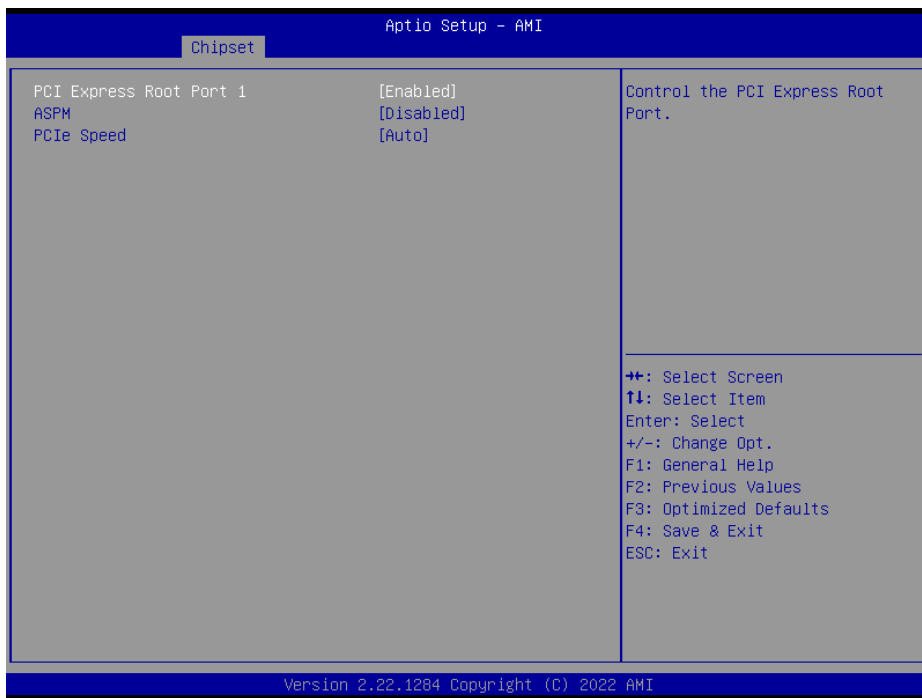

- **PCI Express Root Port 1 [Enabled]**  
Control the PCI express Root Port  
Configuration options: [Enabled] [Disabled]
  - **ASPM [Disabled]**  
Set the ASPM level  
Configuration options: [Disaled] [L0S][L1][L0sL1]
  - **PCIe Speed [Auto]**  
Configure PCIe Speed  
Configuration options: [Auto][Gen1][Gen2][Gen3][Gen4]
- **2.5.1.4.2 PCI Express Root Port 2 (x16 Slot 2)**

## BC680R User's Manual

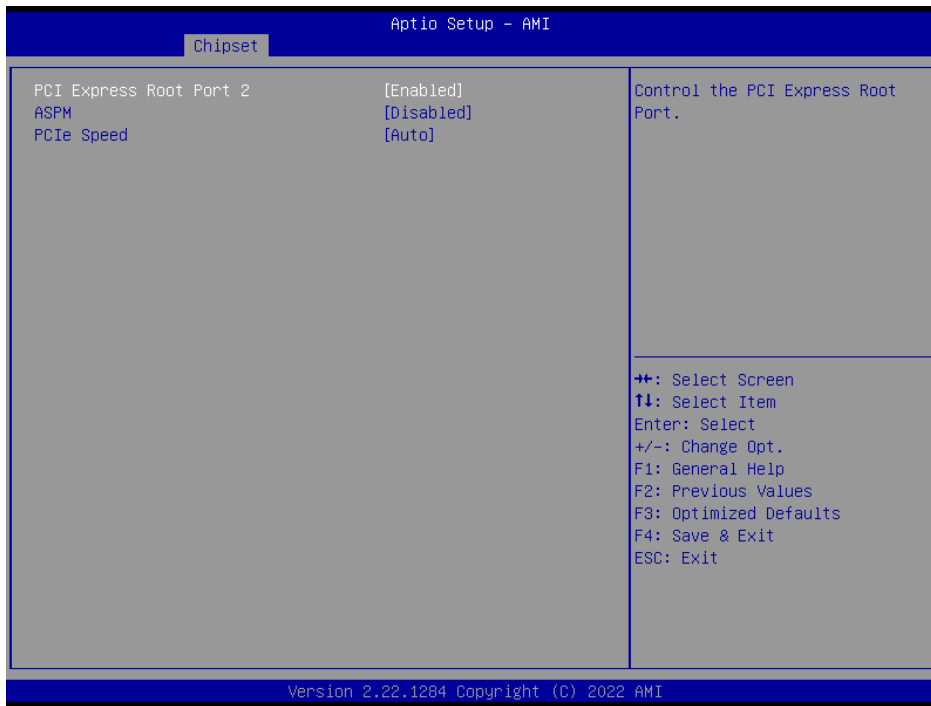

- **PCI Express Root Port 2 [Enabled]**  
Control the PCI express Root Port  
Configuration options: [Enabled] [Disabled]
- **ASPM [Disabled]**  
Set the ASPM level  
Configuration options: [Disaled] [L0S][L1][L0sL1]
- **PCIe Speed [Auto]**  
Configure PCIe Speed  
Configuration options: [Auto][Gen1][Gen2][Gen3][Gen4] [Gen5]

## 2.5.2 PCH-IO Configuration



- **LAN1 Controller [Enabled]**  
Enable or Disable onboard LAN1  
Configuration options: [Disabled][Enabled]
- **LAN1 PXE OpROM [Disabled]**  
Enabled or Disabled boot option for LAN1 controller  
Configuration options: [Disabled][Enabled]
- **LAN2 Controller [Enabled]**  
Enable or Disable onboard LAN2  
Configuration options: [Disabled][Enabled]
- **LAN2 PXE OpROM [Disabled]**  
Enabled or Disabled boot option for LAN2 controller  
Configuration options: [Disabled][Enabled]
- **Restore AC power Loss [Power off]**  
Specify what state to go to when power is re-applied after a power failure(G3 state)  
Configuration options: [Power on][Power off] [Last State]
- **Flash Protection Range Registers(FPRR) [Disabled]**  
Enabled Flash Protection Range Registers  
Configuration options: [Disabled][Enabled]

## BC680R User's Manual

- **GPIO Group Control [Disabled]**

Configure the digital GPIO pins  
Configuration options: [Disabled][Enabled]

- **Amplifier GAIN(db) [15.3db]**

Select Amplifier GAIN value  
Configuration options: [15.3db][21.2db][27.2db][31.8db]

### 2.5.2.1 PCI Express Configuration



#### - 2.5.2.1.1 PCI Express Root Port 1(x4 slot3)

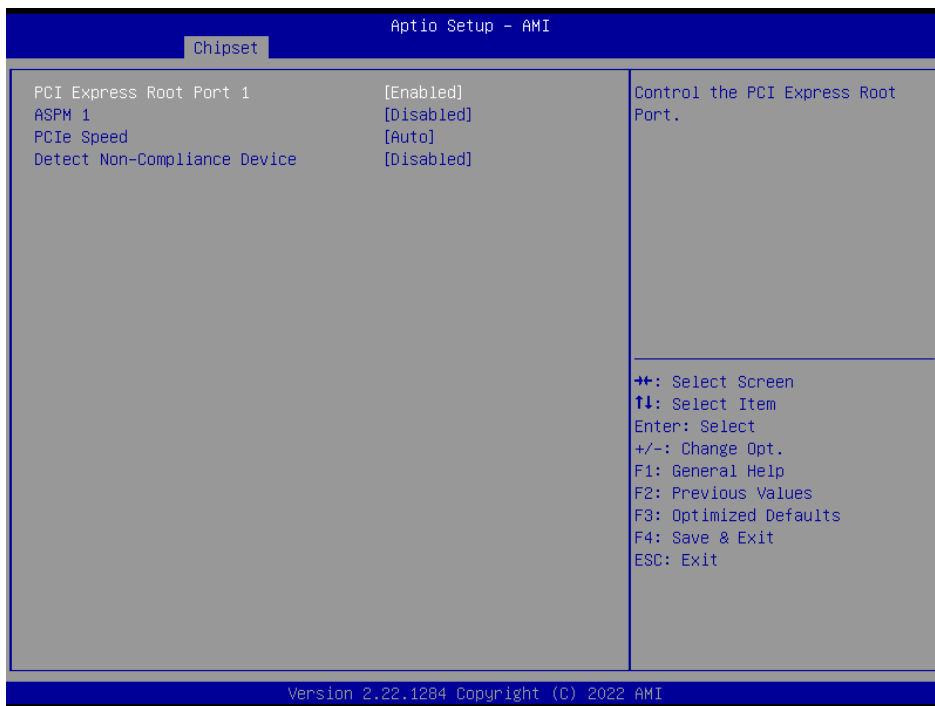

- **PCI Express Root Port 1 [Enabled]**  
Control the PCI Express Port  
Configuration options: [Disabled][Enabled]
- **ASPM 1 [Disabled]**  
Set the ASPM level: Force L0s- Force all links to L0s State; Auto- BIOS auto configure;  
Disabled- Disables ASPM  
Configuration options: [Disabled][L1][Auto]
- **PCIe Speed [Auto]**  
Select PCI Express Port speed  
Configuration options: [Auto][Gen1][Gen2][Gen3] [Gen4]
- **Detect Non-compliance device [Disabled]**  
Detect non-compliance PCI express Device, If enabled, it will take more time at Post time.  
Configuration options: [Disabled][Enabled]



## BC680R User's Manual

### - 2.5.2.1.2 PCI Express Root Port 5(x1 Slot 1)

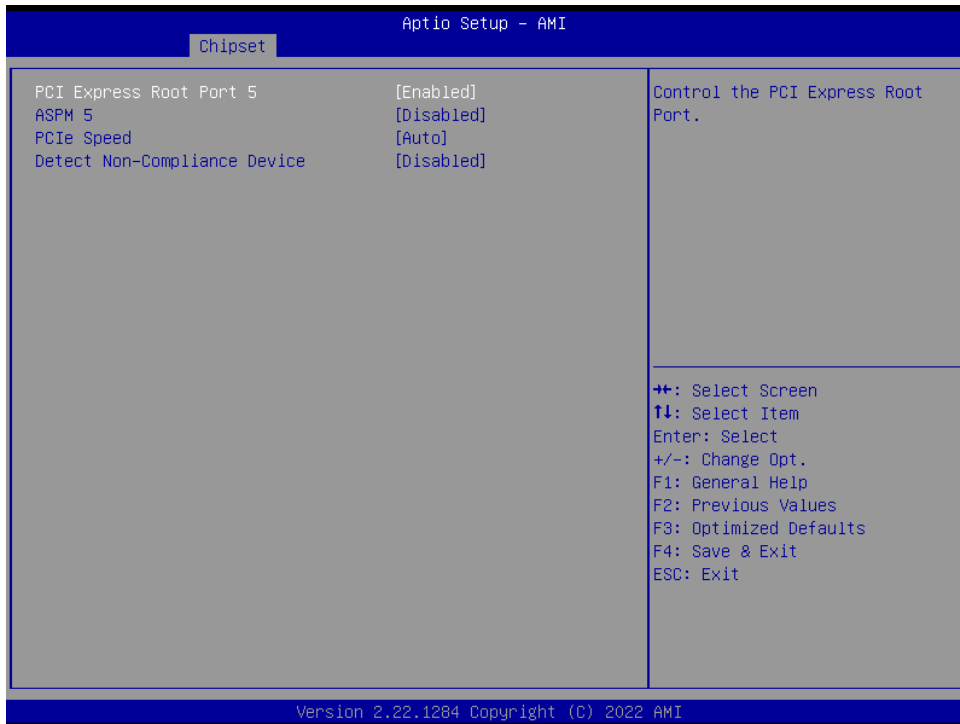

- **PCI Express Root Port 5 [Enabled]**

Control the PCI Express Port

Configuration options: [Disabled][Enabled]

- **ASPM 5 [Disabled]**

Set the ASPM level: Force L0s- Force all links to L0s State; Auto- BIOS auto configure; Disabled- Disables ASPM

Configuration options: [Disabled][L1][Auto]

- **PCIe Speed [Auto]**

Select PCI Express Port speed

Configuration options: [Auto][Gen1][Gen2][Gen3] [Gen4]

- **Detect Non-compliance device [Disabled]**

Detect non-compliance PCI express Device, If enabled, it will take more time at Post time.

Configuration options: [Disabled][Enabled]

## - 2.5.2.1.3 PCI Express Root Port 6(X1 Slot 5)

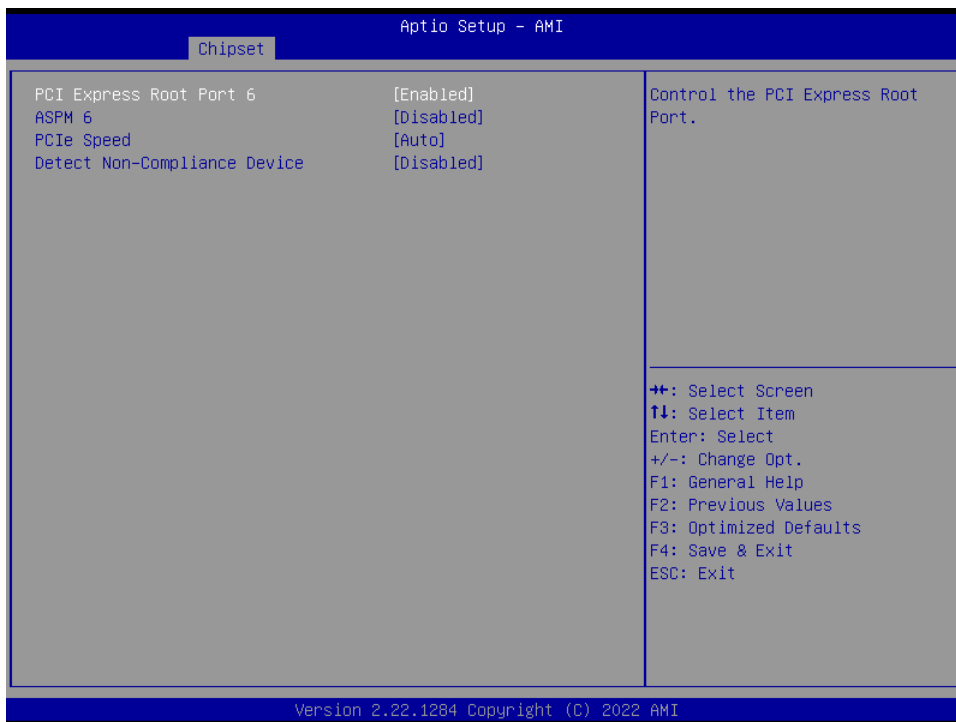

- **PCI Express Root Port 6 [Enabled]**  
Control the PCI Express Port  
Configuration options: [Disabled][Enabled]
- **ASPM 6 [Disabled]**  
Set the ASPM level: Force L0s- Force all links to L0s State; Auto- BIOS auto configure;  
Disabled- Disables ASPM  
Configuration options: [Disabled][L1][Auto]
- **PCIe Speed [Auto]**  
Select PCI Express Port speed  
Configuration options: [Auto][Gen1][Gen2][Gen3] [Gen4]
- **Detect Non-compliance device [Disabled]**  
Detect non-compliance PCI express Device, If enabled, it will take more time at Post time.  
Configuration options: [Disabled][Enabled]

## BC680R User's Manual

### - 2.5.2.1.4 PCI Express Root Port 7(x1 slot 6)

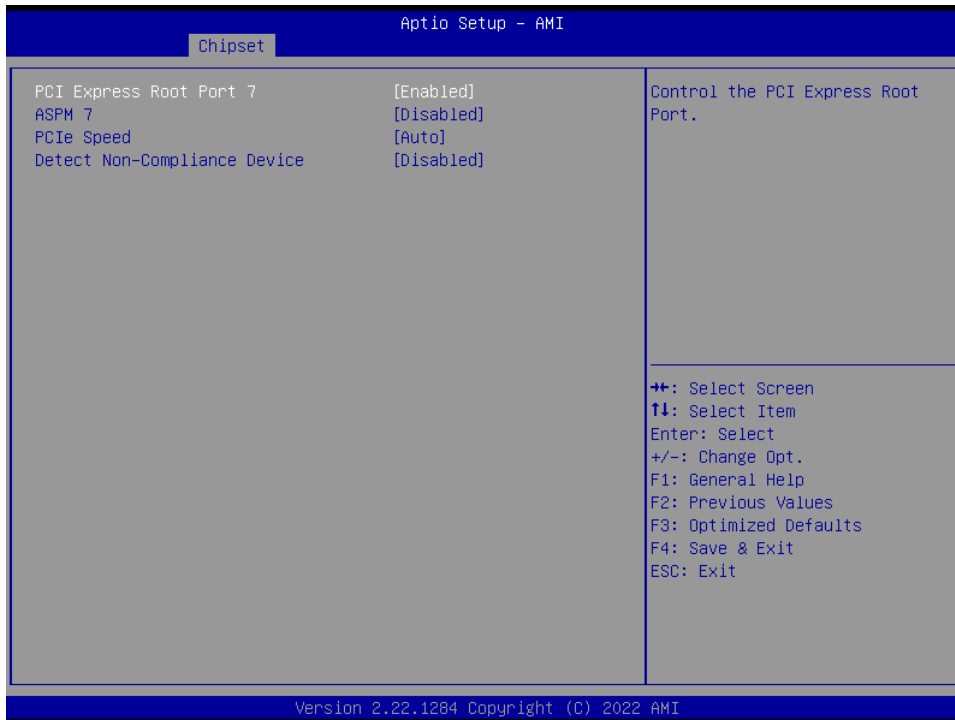

- **PCI Express Root Port 7 [Enabled]**

Control the PCI Express Port

Configuration options: [Disabled][Enabled]

- **ASPM 7 [Disabled]**

Set the ASPM level: Force L0s- Force all links to L0s State; Auto- BIOS auto configure; Disabled- Disables ASPM

Configuration options: [Disabled][L1][Auto]

- **PCIe Speed [Auto]**

Select PCI Express Port speed

Configuration options: [Auto][Gen1][Gen2][Gen3] [Gen4]

- **Detect Non-compliance device [Disabled]**

Detect non-compliance PCI express Device, If enabled, it will take more time at Post time.

Configuration options: [Disabled][Enabled]

### - 2.5.2.1.5 PCI Express Root Port 8(x1 keyE)



- **PCI Express Root Port 8 [Enabled]**  
Control the PCI Express Port  
Configuration options: [Disabled][Enabled]
  - **ASPM 8 [Disabled]**  
Set the ASPM level: Force L0s- Force all links to L0s State; Auto- BIOS auto configure;  
Disabled- Disables ASPM  
Configuration options: [Disabled][L1][Auto]
  - **PCIe Speed [Auto]**  
Select PCI Express Port speed  
Configuration options: [Auto][Gen1][Gen2][Gen3] [Gen4]
  - **Detect Non-compliance device [Disabled]**  
Detect non-compliance PCI express Device, If enabled, it will take more time at Post time.  
Configuration options: [Disabled][Enabled]
- **2.5.2.1.6 PCI Express Root Port 13(x4 Key M)**

# BC680R User's Manual

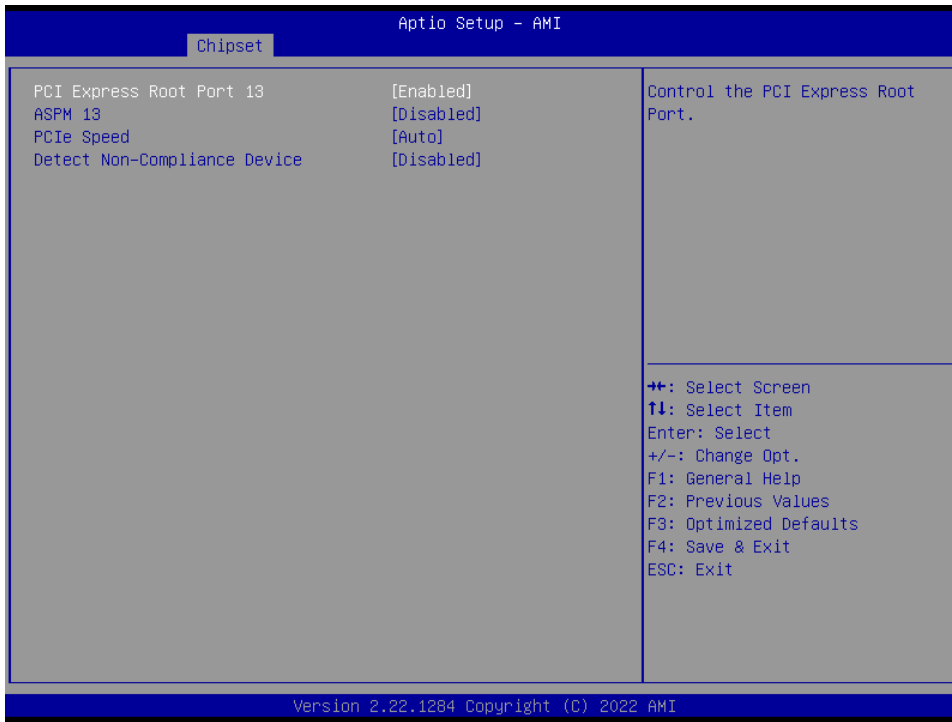

- **PCI Express Root Port 13 [Enabled]**

Control the PCI Express Port

Configuration options: [Disabled][Enabled]

- **ASPM 13 [Disabled]**

Set the ASPM level: Force L0s- Force all links to L0s State; Auto- BIOS auto configure; Disabled- Disables ASPM

Configuration options: [Disabled][L1][Auto]

- **PCIe Speed [Auto]**

Select PCI Express Port speed

Configuration options: [Auto][Gen1][Gen2][Gen3] [Gen4]

- **Detect Non-compliance device [Disabled]**

Detect non-compliance PCI express Device, If enabled, it will take more time at Post time.

Configuration options: [Disabled][Enabled]

- **2.5.2.1.7 PCI Express Root Port 21(x4 slot 4)**

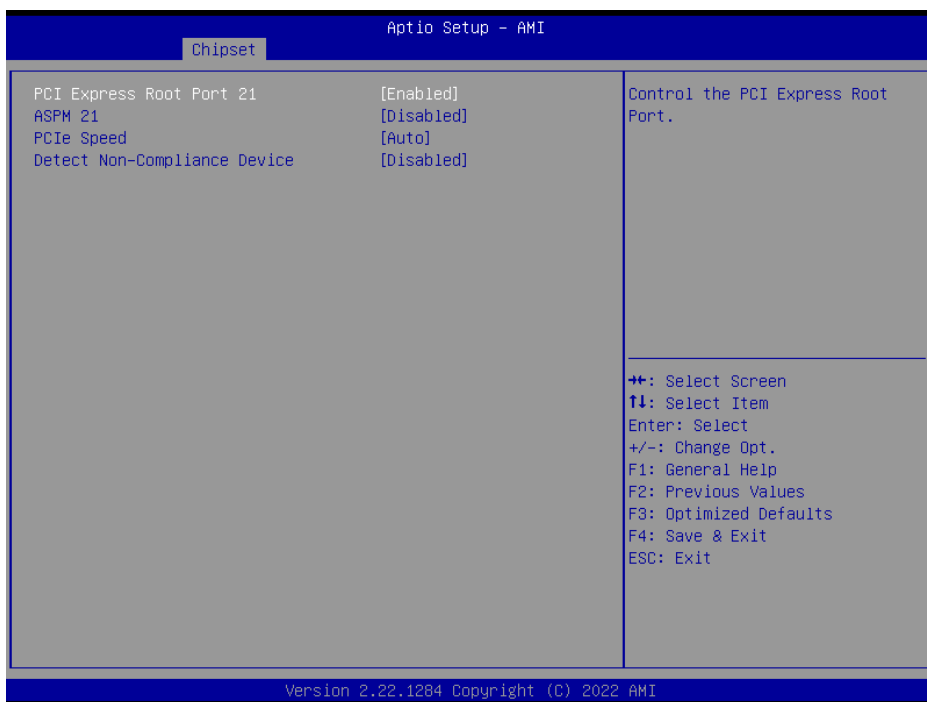

- **PCI Express Root Port 21 [Enabled]**  
Control the PCI Express Port  
Configuration options: [Disabled][Enabled]
  - **ASPM 21 [Disabled]**  
Set the ASPM level: Force L0s- Force all links to L0s State; Auto- BIOS auto configure;  
Disabled- Disables ASPM  
Configuration options: [Disabled][L1][Auto]
  - **PCIe Speed [Auto]**  
Select PCI Express Port speed  
Configuration options: [Auto][Gen1][Gen2][Gen3] [Gen4]
  - **Detect Non-compliance device [Disabled]**  
Detect non-compliance PCI express Device, If enabled, it will take more time at Post time.  
Configuration options: [Disabled][Enabled]
- **2.5.2.1.8 PCI Express Root Port 25(x4 slot 7)**

# BC680R User's Manual

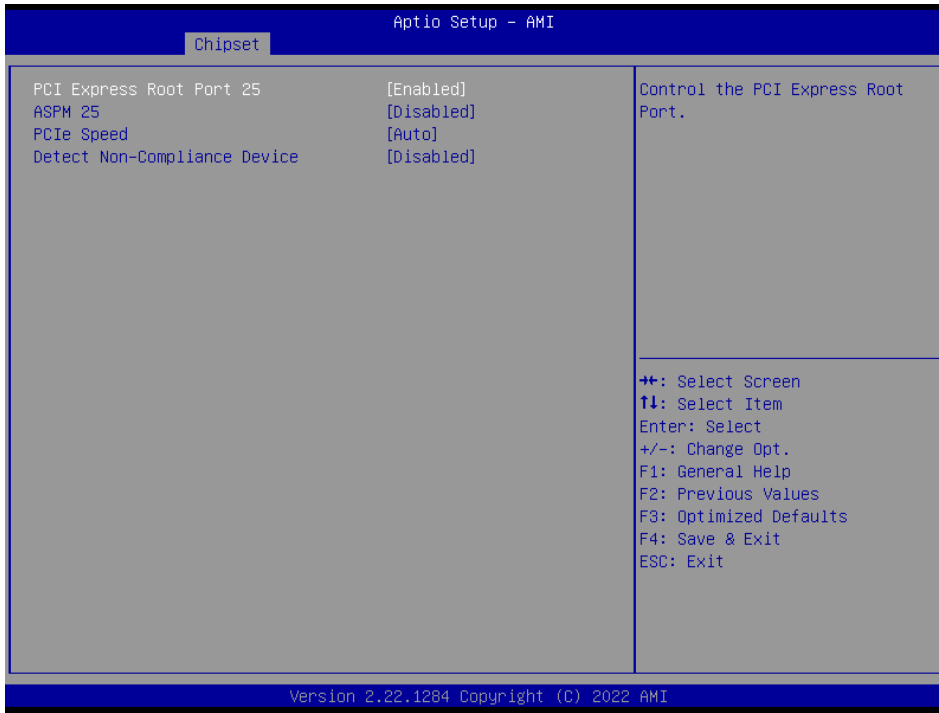

- **PCI Express Root Port 25 [Enabled]**  
Control the PCI Express Port  
Configuration options: [Disabled][Enabled]
- **ASPM 25 [Disabled]**  
Set the ASPM level: Force L0s- Force all links to L0s State; Auto- BIOS auto configure;  
Disabled- Disables ASPM  
Configuration options: [Disabled][L1][Auto]
- **PCIe Speed [Auto]**  
Select PCI Express Port speed  
Configuration options: [Auto][Gen1][Gen2][Gen3] [Gen4]
- **Detect Non-compliance device [Disabled]**  
Detect non-compliance PCI express Device, If enabled, it will take more time at Post time.  
Configuration options: [Disabled][Enabled]

### 2.5.2.2 SATA Configuration

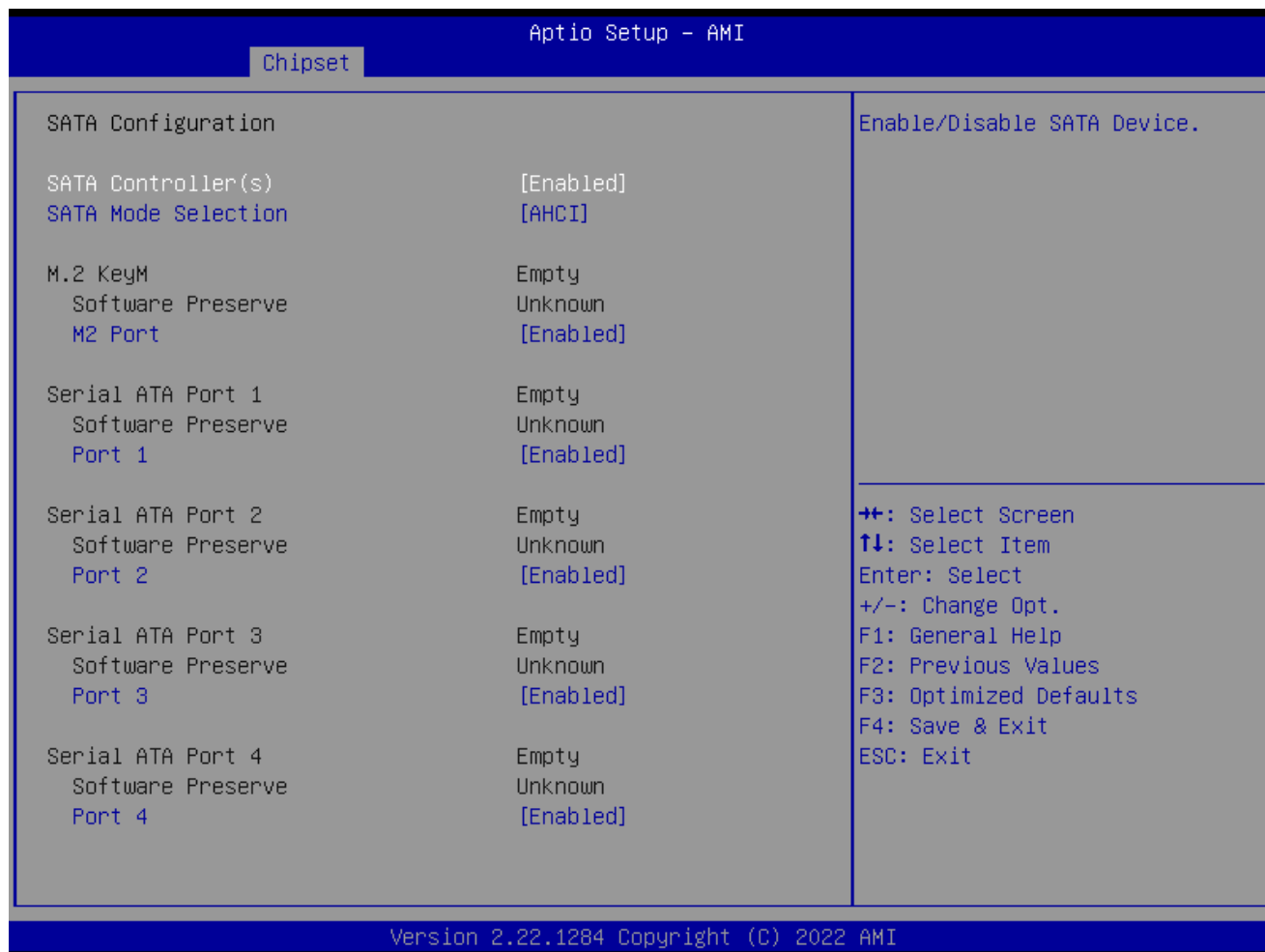

- **SATA Controller(s) [Enabled]**  
Enable or Disable SATA device  
Configuration options: [Enabled][Disabled]
- **SATA Mode Selection [AHCI]**  
Determines how SATA controller operate  
Configuration options: [AHCI]
- **M.2 Port [Enabled]**  
Enable or Disable M.2 port  
Configuration options: [Enabled][Disabled]
- **Port 1 [Enabled]**  
Enable or Disable SATA port 1  
Configuration options: [Enabled][Disabled]
- **Port 2 [Enabled]**  
Enable or Disable SATA port 2  
Configuration options: [Enable ][Disabled]
- **Port 3 [Enabled]**  
Enable or Disable SATA port 3  
Configuration options: [Enabled][Disabled]



## BC680R User's Manual

- **Port 4 [Enabled]**

Enable or Disable SATA port 4

Configuration options: [Enabled][Disabled]

### 2.5.2.3 USB Configuration

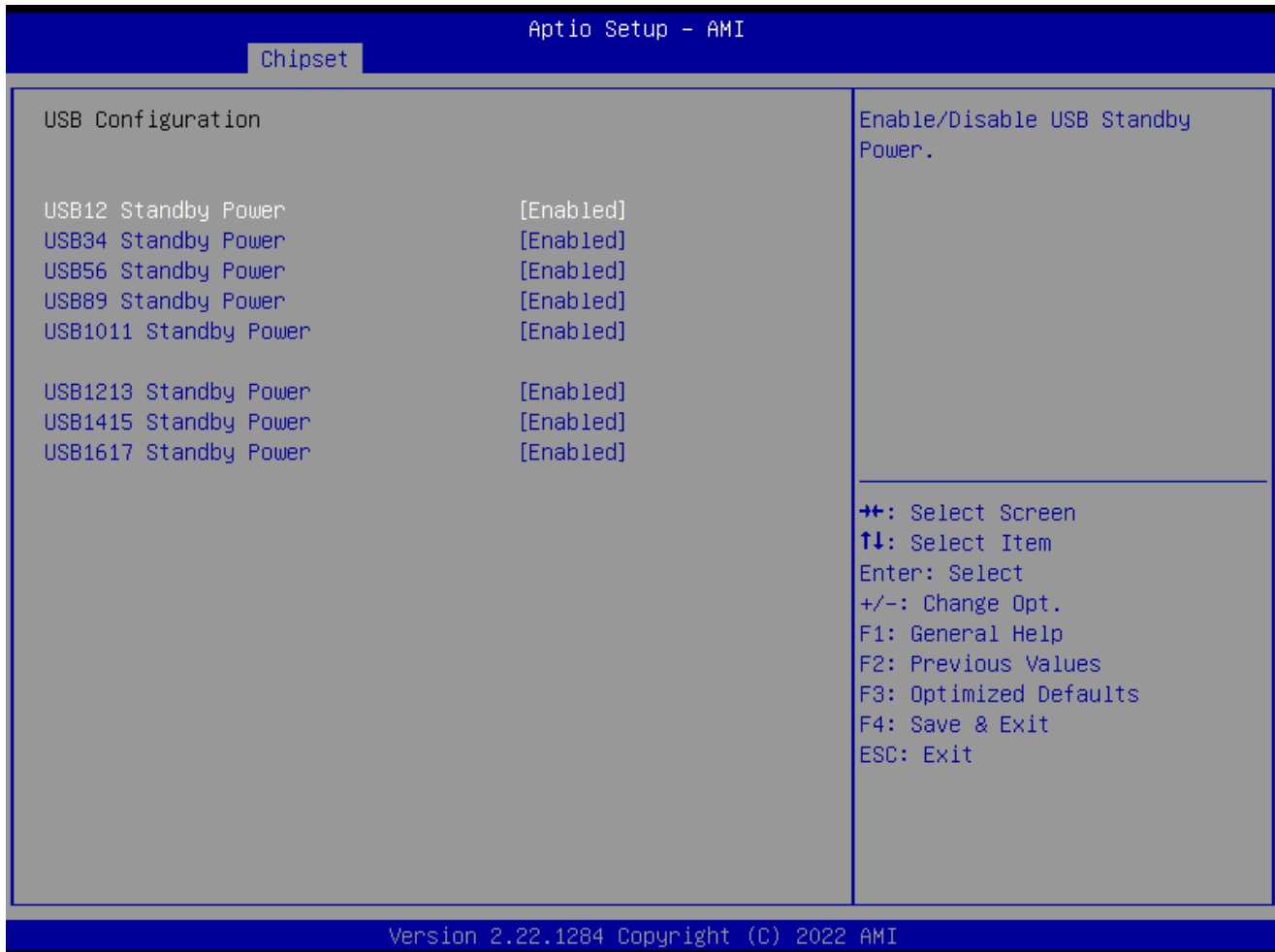

- **USB12 Standby Power[Enabled]**

Enable or Disable USB standby power

Configuration options: [Disabled] [Enabled]

- **USB34 Standby Power[Enabled]**

Enable or Disable USB standby power

Configuration options: [Disabled] [Enabled]

- **USB56 Standby Power[Enabled]**

Enable or Disable USB standby power

Configuration options: [Disabled] [Enabled]

- **USB89 Standby Power[Enabled]**

Enable or Disable USB standby power

Configuration options: [Disabled] [Enabled]

- **USB1011 Standby Power[Enabled]**

Enable or Disable USB standby power

Configuration options: [Disabled] [Enabled]

- **USB1213 Standby Power[Enabled]**  
Enable or Disable USB standby power  
Configuration options: [Disabled] [Enabled]
- **USB1415 Standby Power[Enabled]**  
Enable or Disable USB standby power  
Configuration options: [Disabled] [Enabled]
- **USB1617 Standby Power[Enabled]**  
Enable or Disable USB standby power  
Configuration options: [Disabled] [Enabled]

#### 2.5.2.4 HD audio Configuration

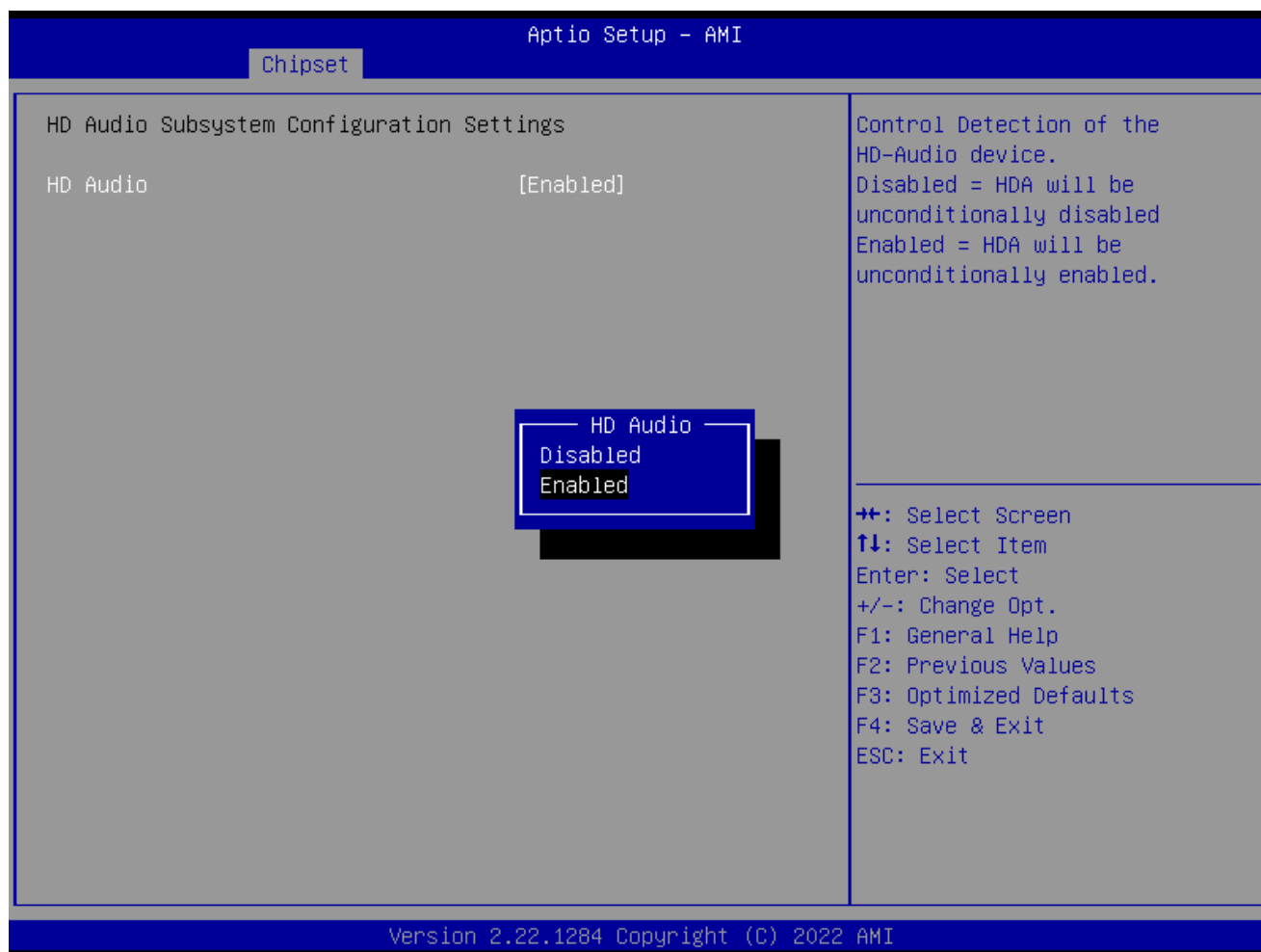

- **HD audio[Enabled]**  
Control Detection of the HD-Audio device.  
Configuration options: [Disabled] [Enabled]

**BC680R User's Manual**  
**2.5.2.5 Serial IO Configuration**

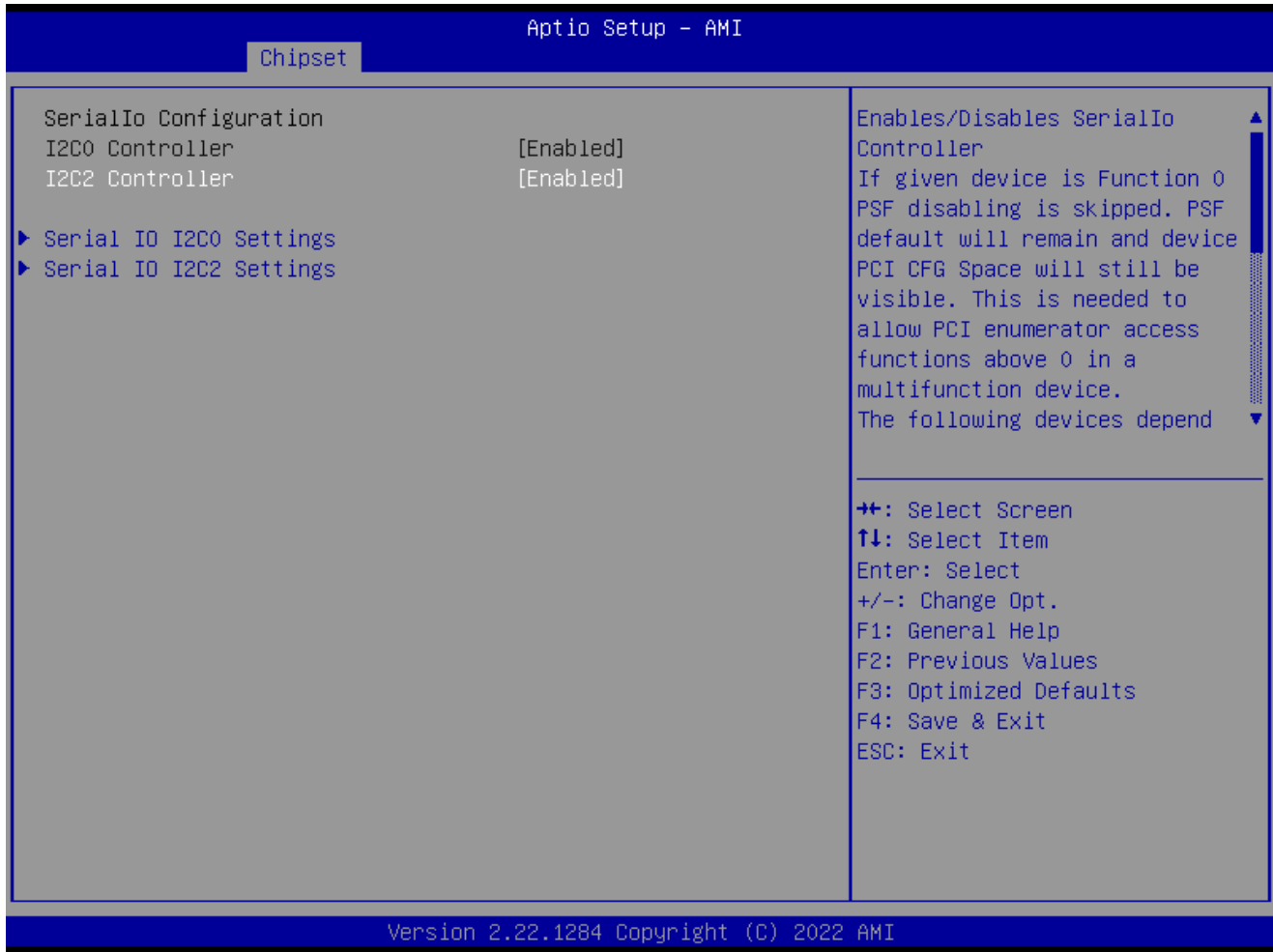

- **I2C0 Controller[Enabled]**  
Enabled/Disabled Serial IO Controller  
Configuration options: [Disabled] [Enabled]
- **I2C2 Controller[Enabled]**  
Enabled/Disabled Serial IO Controller  
Configuration options: [Disabled] [Enabled]

## 2.6 Security

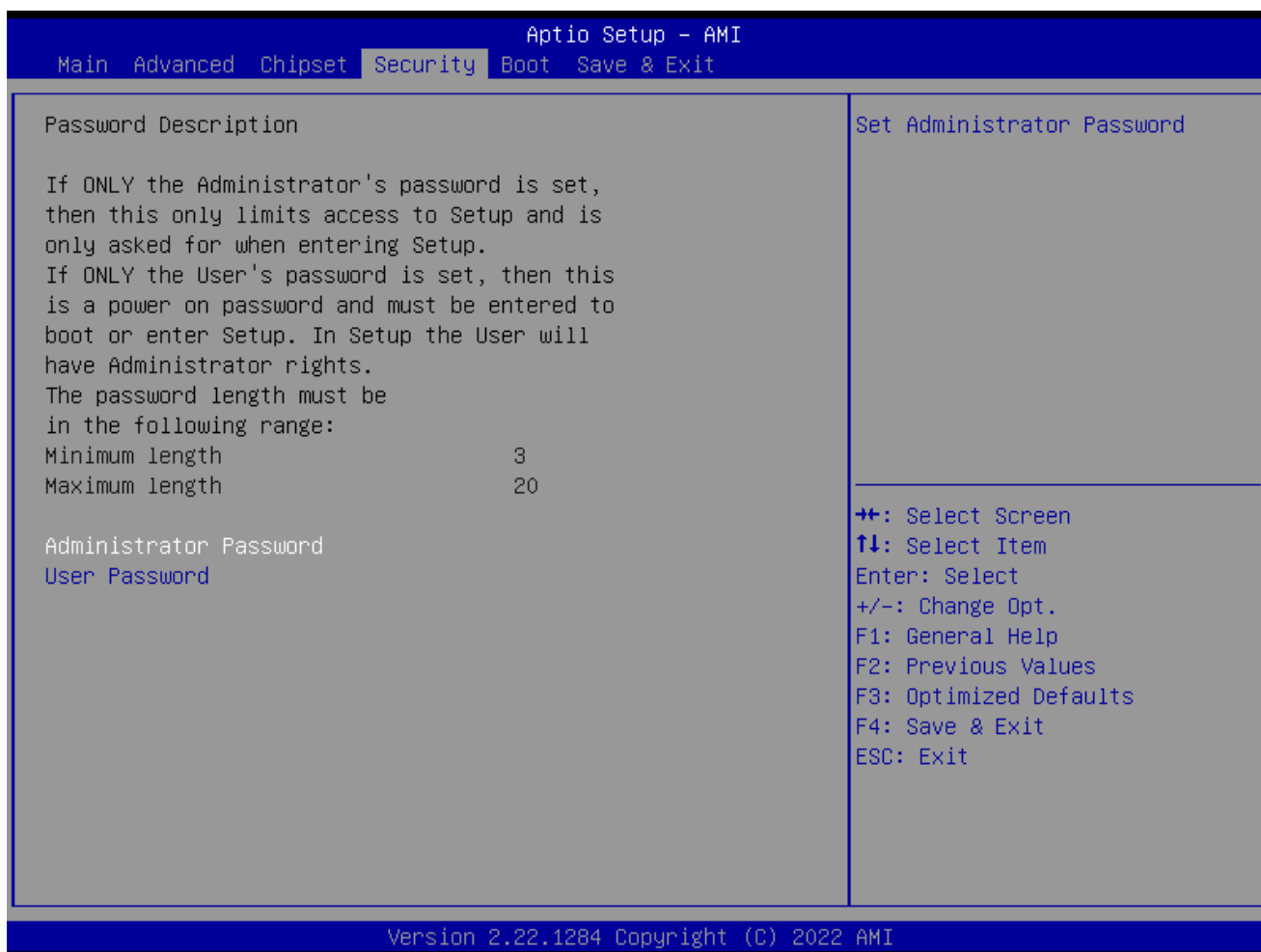

- **Administrator Password**  
Set Administrator Password
- **User Password**  
Set User Password

2.7 Boot

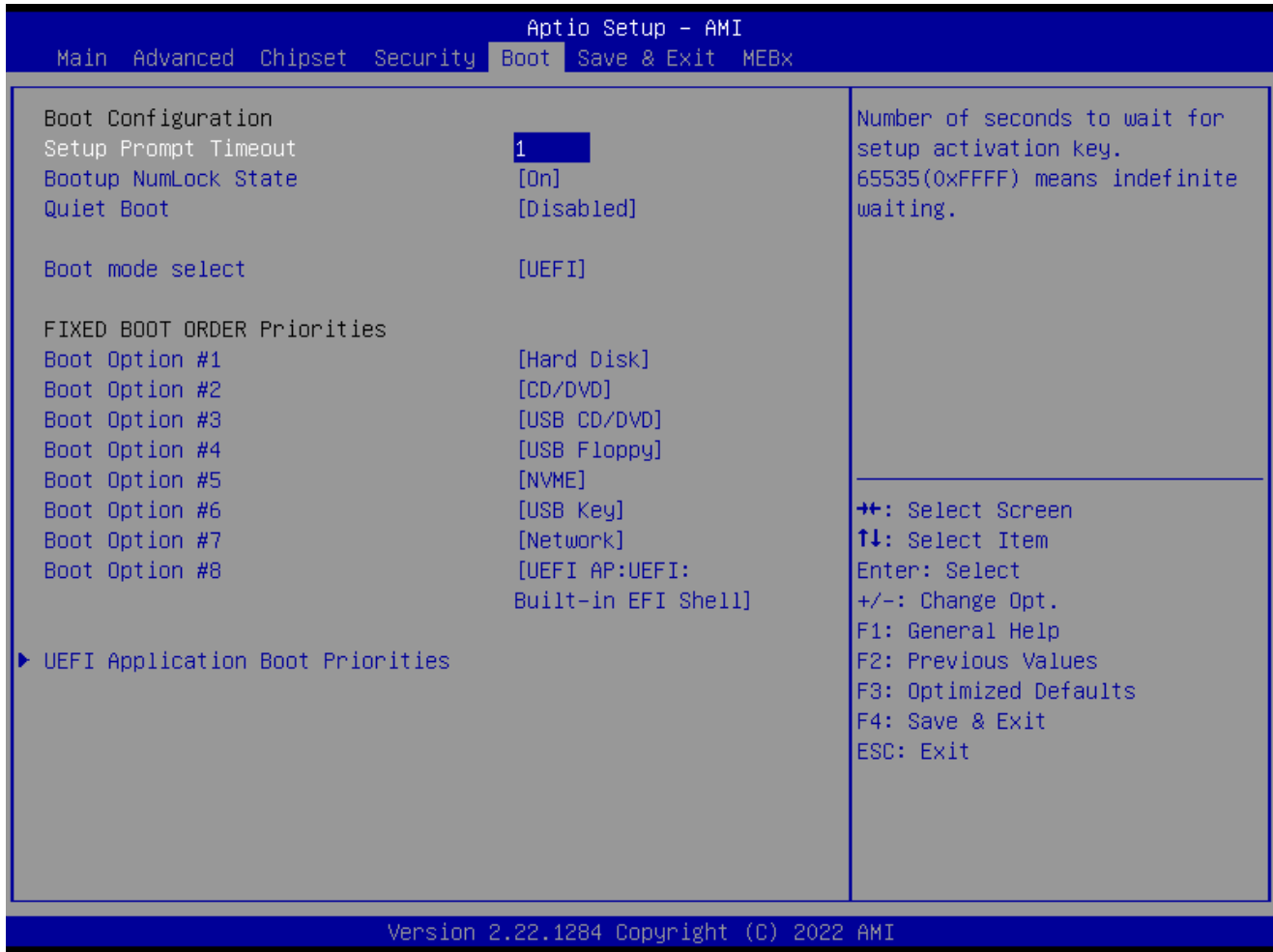

- **Setup Prompt Timeout [1]**  
Number of seconds to wait for setup activation key. 65535(0xFFFF) means indefinite waiting.
- **Bootup NumLock State [On]**  
Select the keyboard NumLock state  
Configuration options: [On] [Off]
- **Quick Boot [Disable]**  
Enable or disable Quick Boot option  
Configuration options: [Disabled] [Enabled]
- **Boot mode select [UEFI]**  
Select boot mode LEGACY/UEFI  
Configuration options: [UEFI]
- **UEFI Application Boot Priorities**  
Specifies the boot device priority sequence from available UEFI Application.

## 2.8 Save & Exit

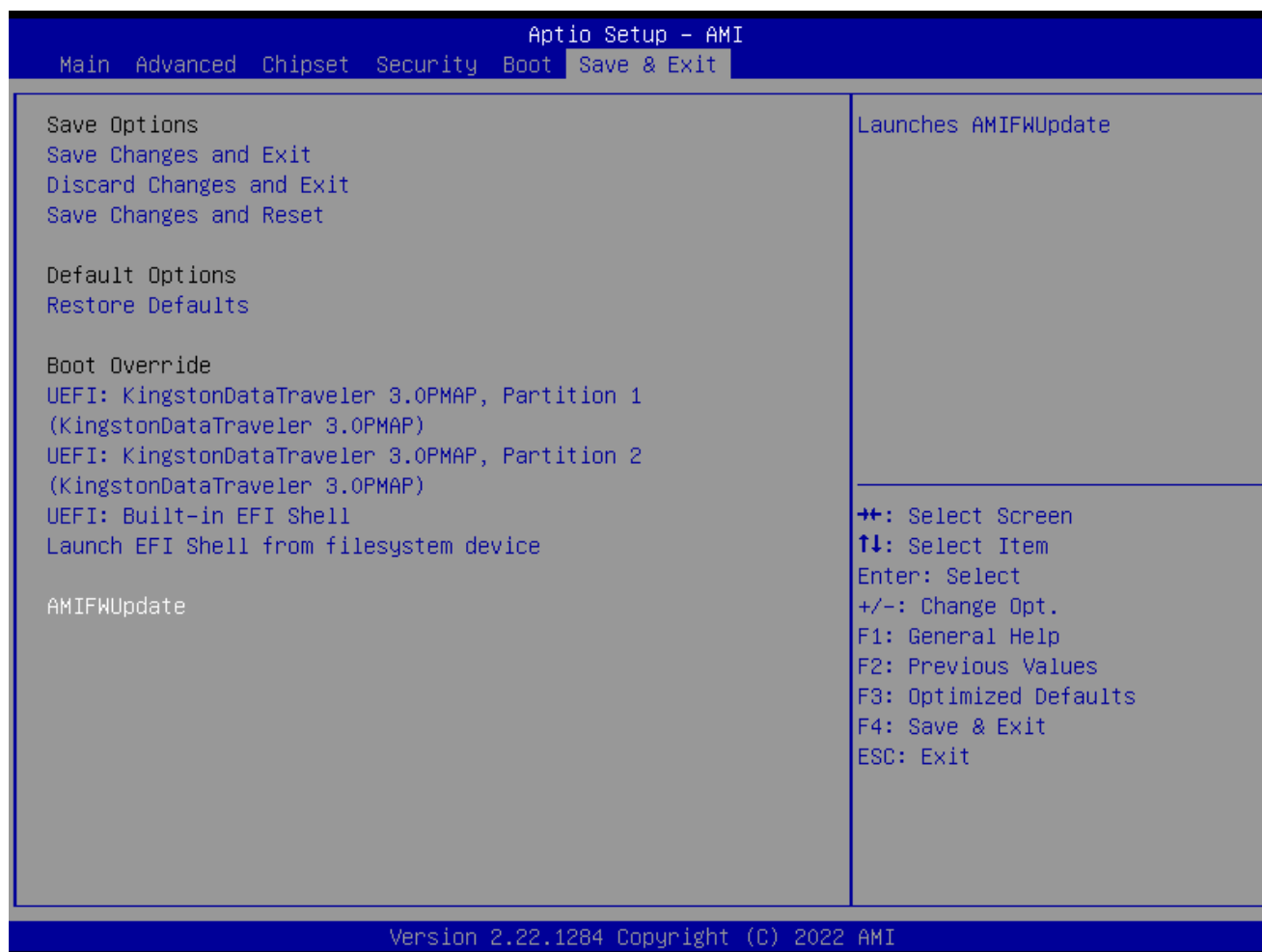

- **Save changes and Exit**  
Exit system setup after saving the changes.
- **Discard changes and Exit**  
Exit system setup without saving the changes.
- **Save changes and Reset**  
Reset the system after saving the changes.
- **Restore Defaults**  
Restore/Load default values for all the setup option.
- **Launch EFI Shell from filesystem device**  
Attempts to launch EFI shell application from one of the available filesystem devices.
- **AMIFWUpdate**  
Launches AMIFWUpdate